

# APOLLO 18



Narzędzia potrzebne do montażu



## UWAGA !!!

MONTOWANIE USZKODZONYCH  
ELEMENTÓW POWODUJE UTRATĘ  
GWARANCJI

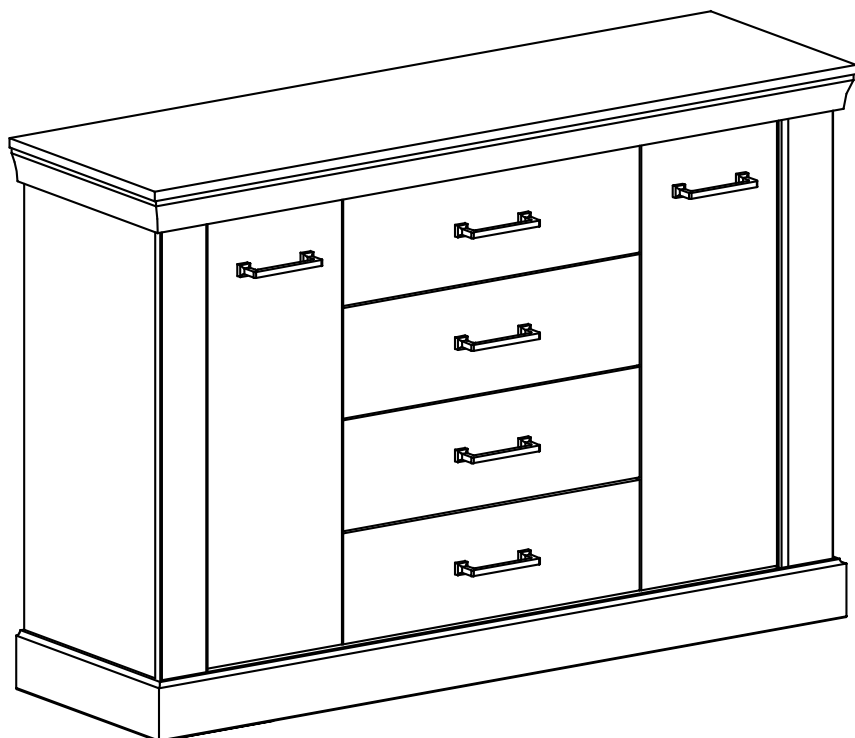

W przypadku reklamacji proszę podać numer pakowacza znajdujący się na kartonie.

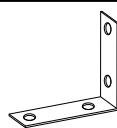

**Y - 2 St.**

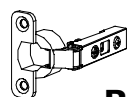

**R2 - 2 St.**



**W2 - 2 St.**

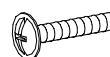

**D - 12 St.**  
4x25 mm



**I - 4 St.**  
3,5x16 mm

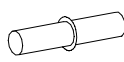

**F - 8 St.**



**W1 - 2 St.**

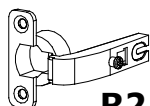

**R2 - 2 St.**



**M - 56 St.**  
3x30 mm



**E - 90 St.**



**Z - 1 St.**

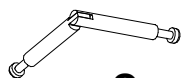

**O - 4 St.**

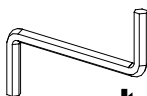

**Ł - 1 St.**

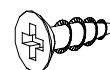

**G - 8 St.**  
3,5x16 mm



**L - 26 St.**



**J - 32 St.**  
5x13 mm



**A - 9 St.**  
7x50 mm

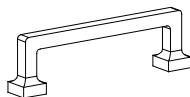

**U - 6 St.**

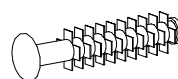

**P - 16 St.**

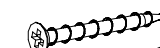

**C - 8 St.**  
3,9x30 mm

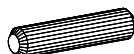

**B - 32 St.**



**Q - 6 St.**

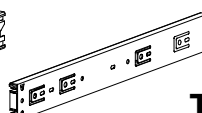
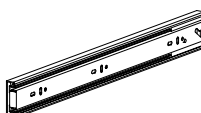

**T - 4 Kpl.**

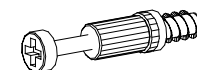

**K - 18 St.**

I

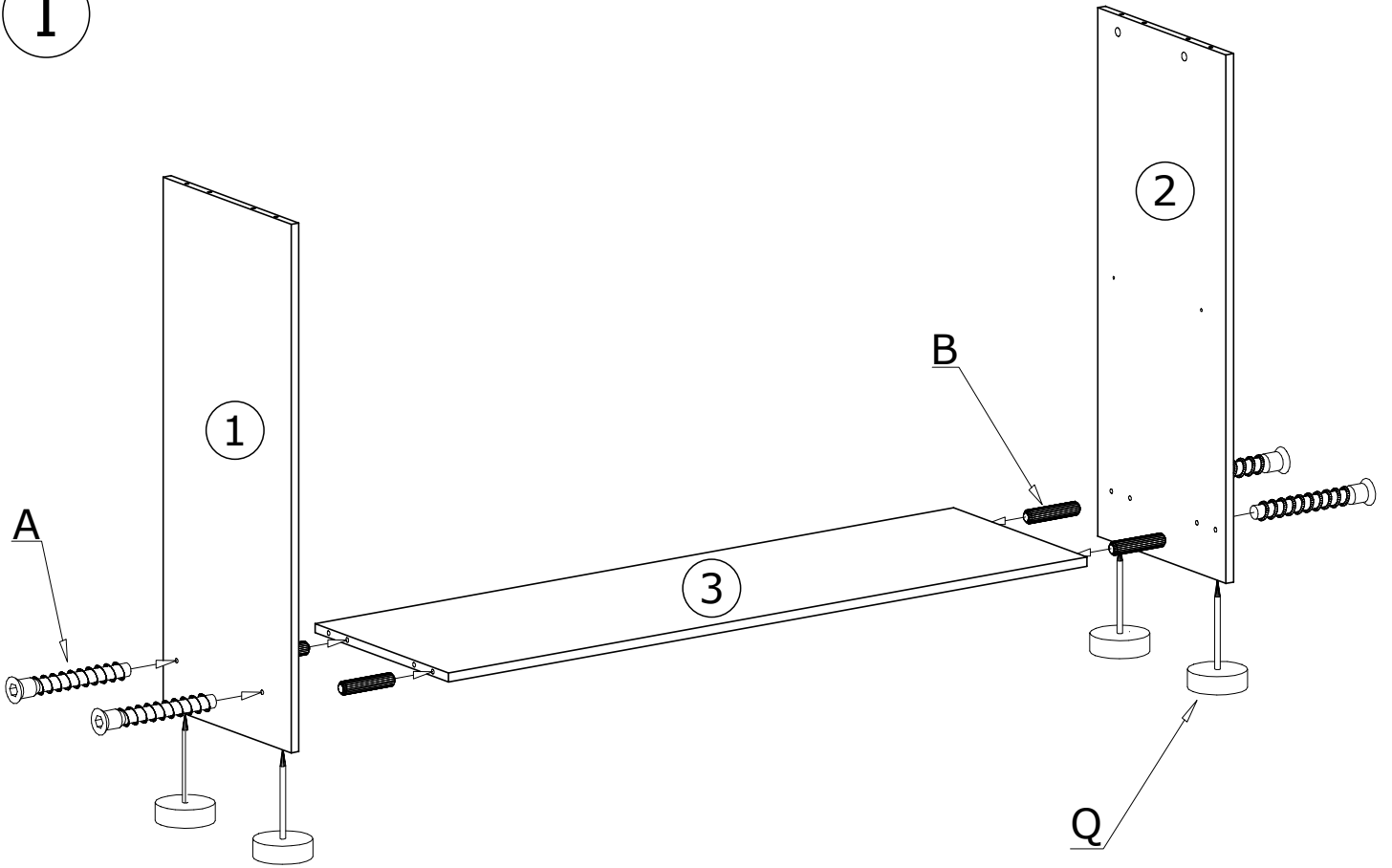

II

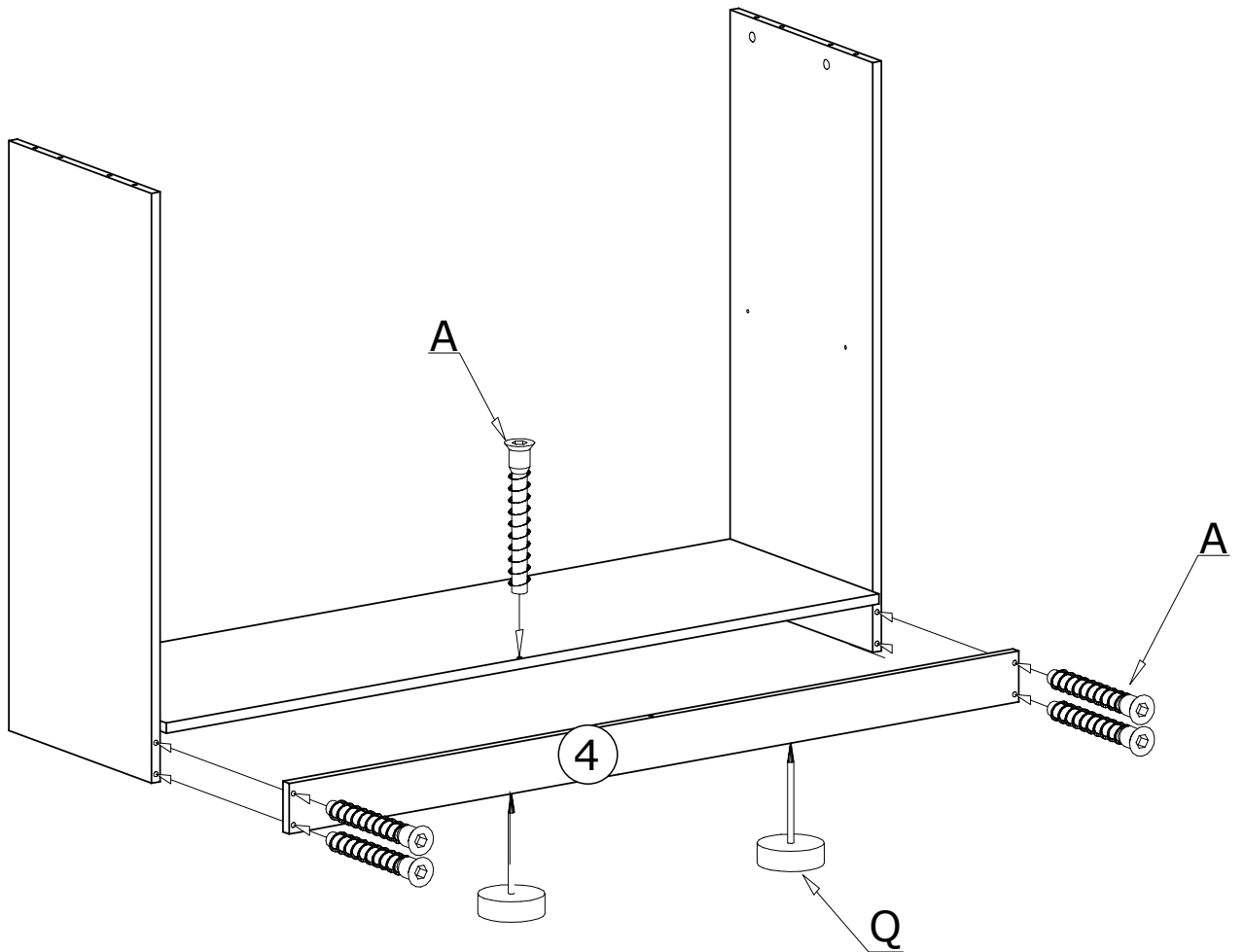

III

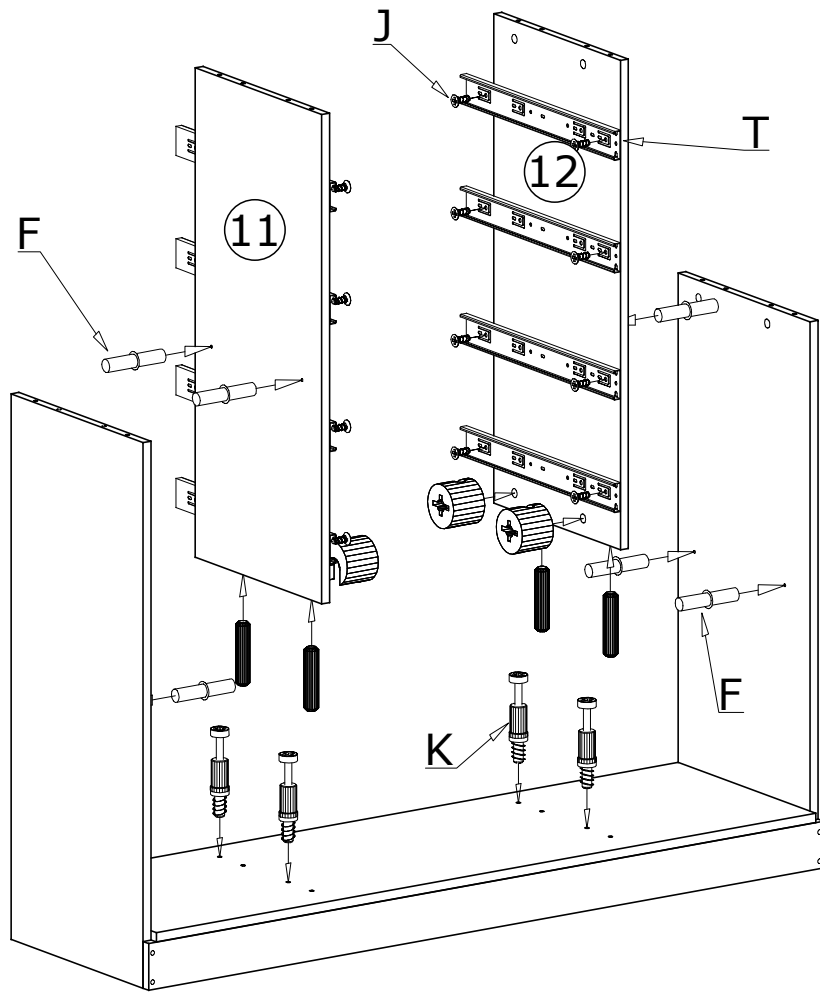

IV

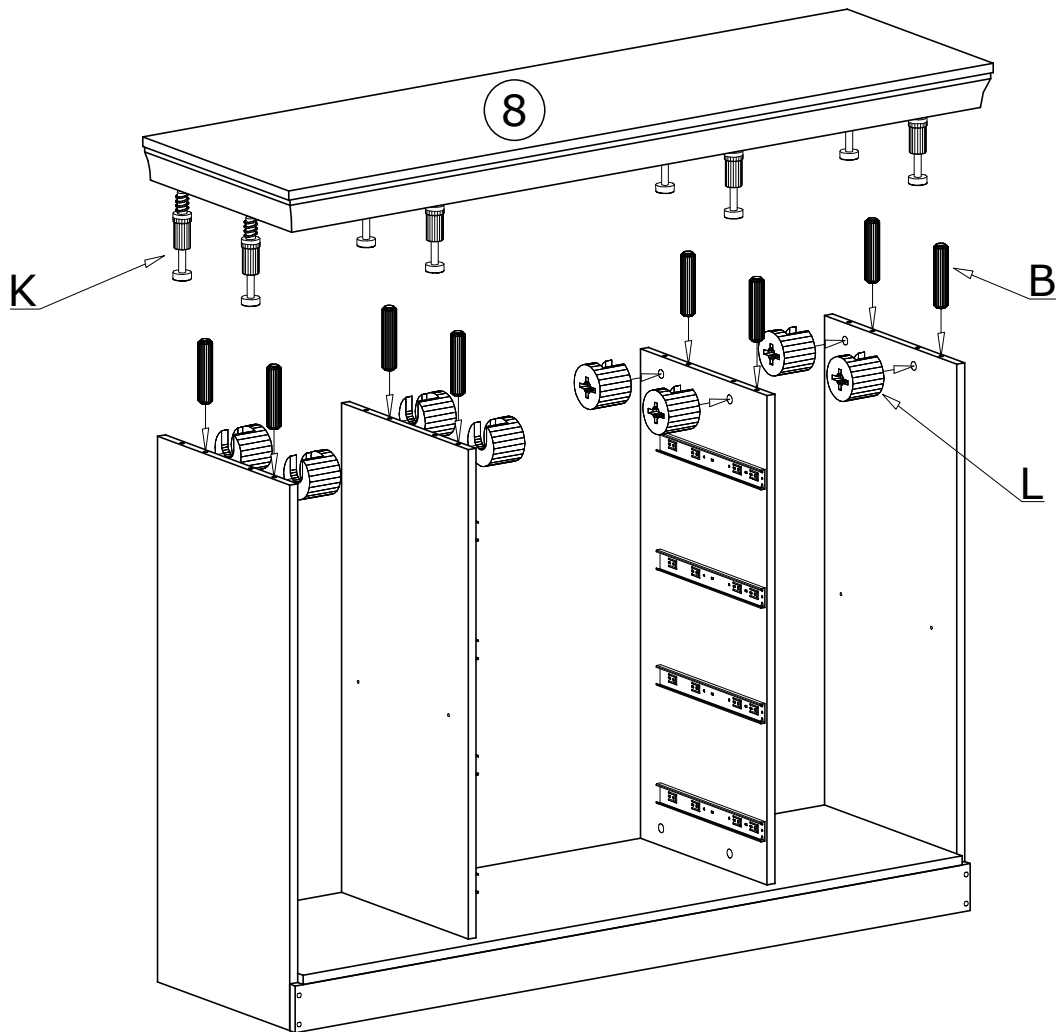

V

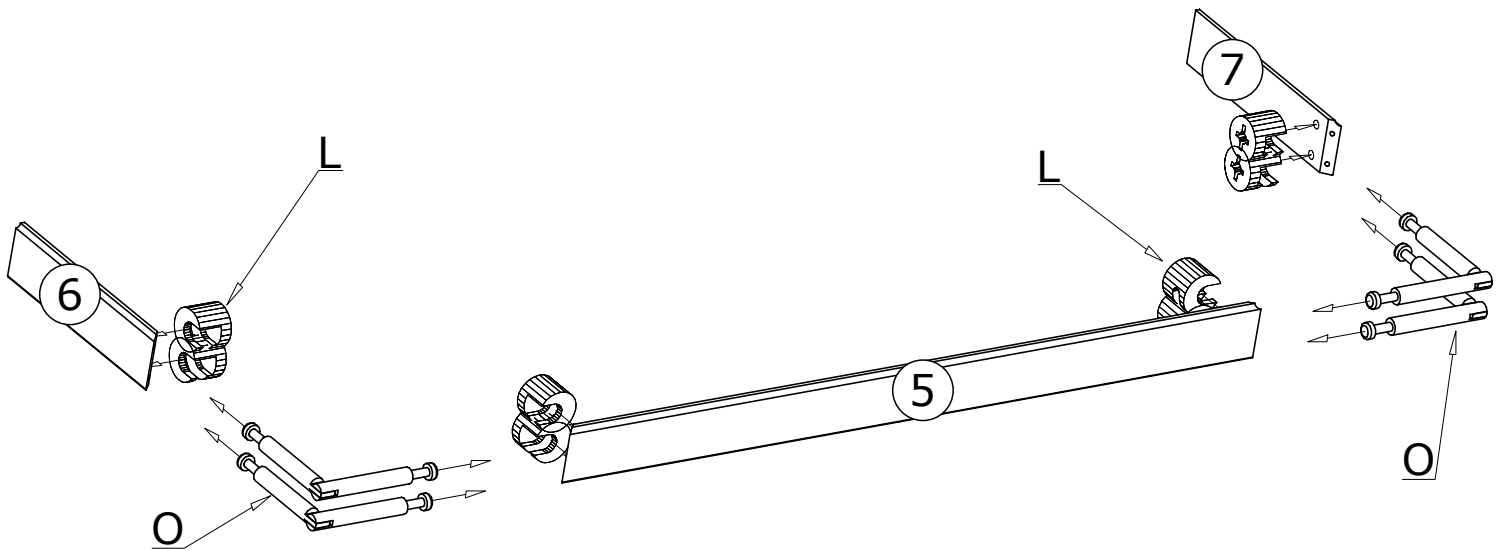

VI

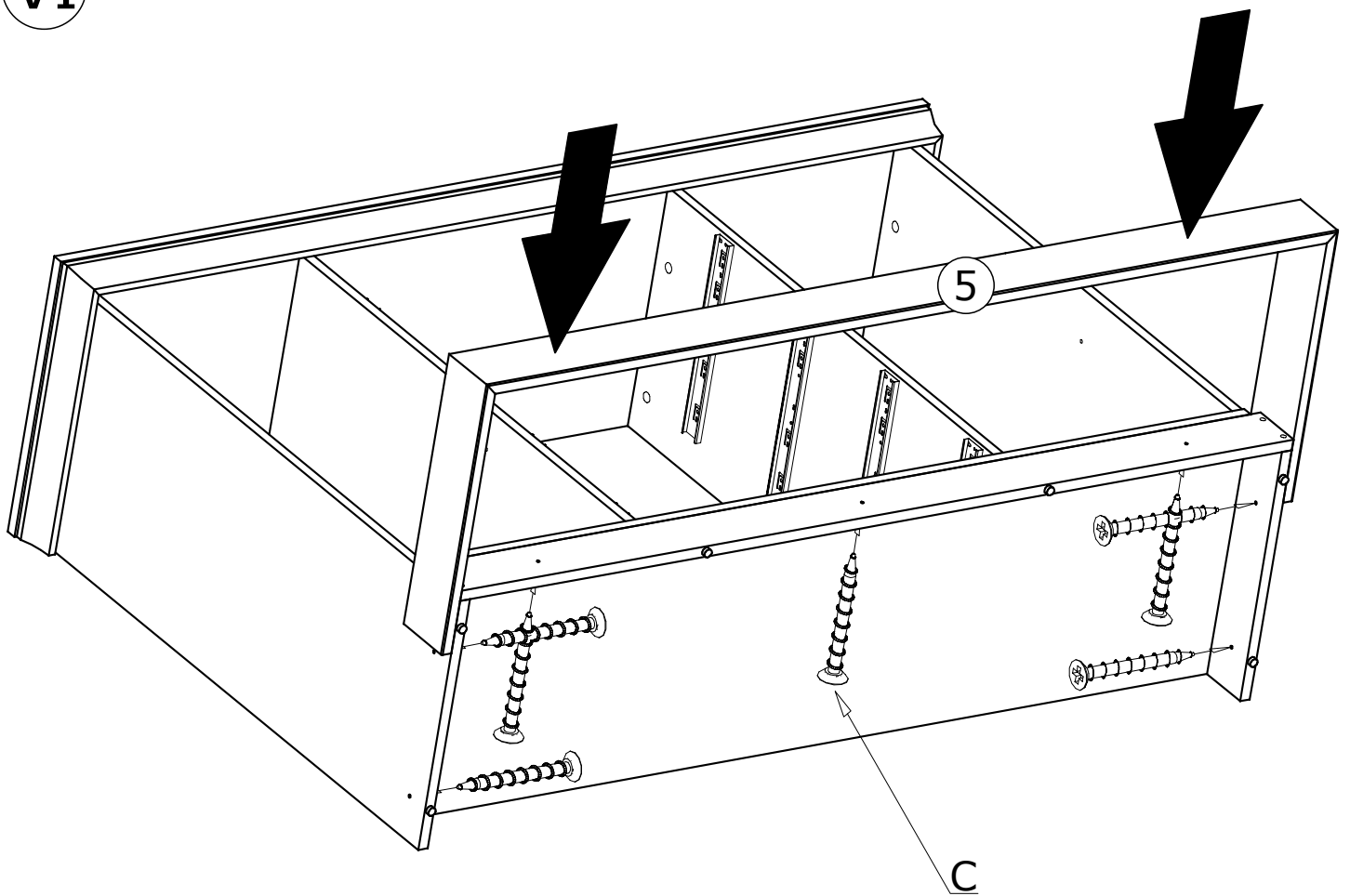

VII

90X 

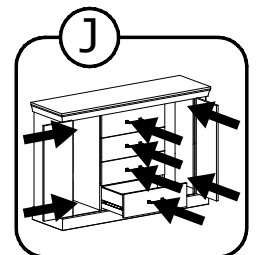
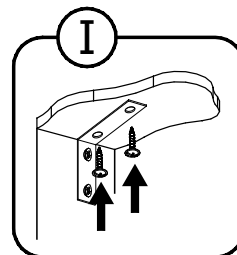
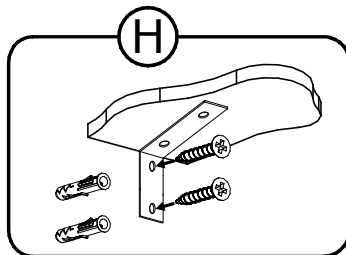
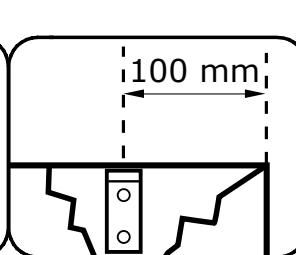
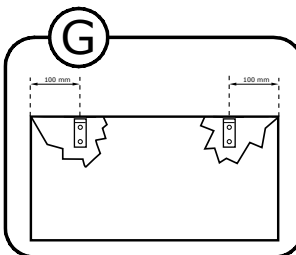
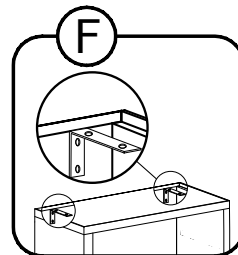
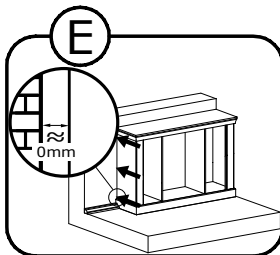
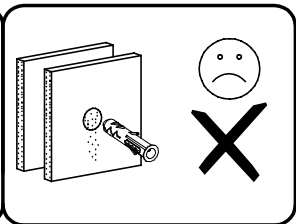
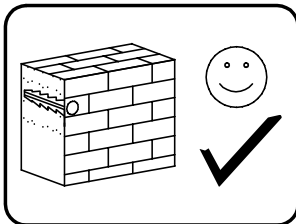
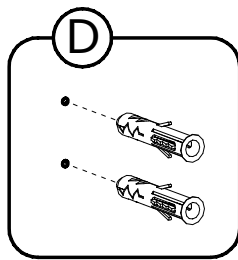
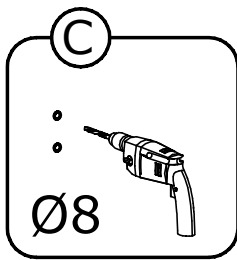
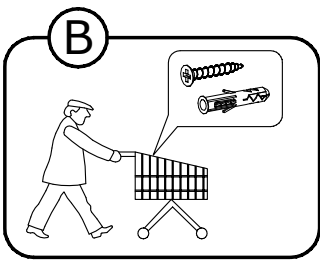
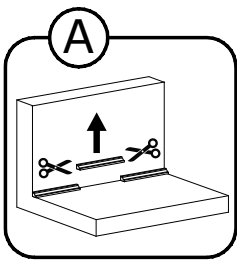
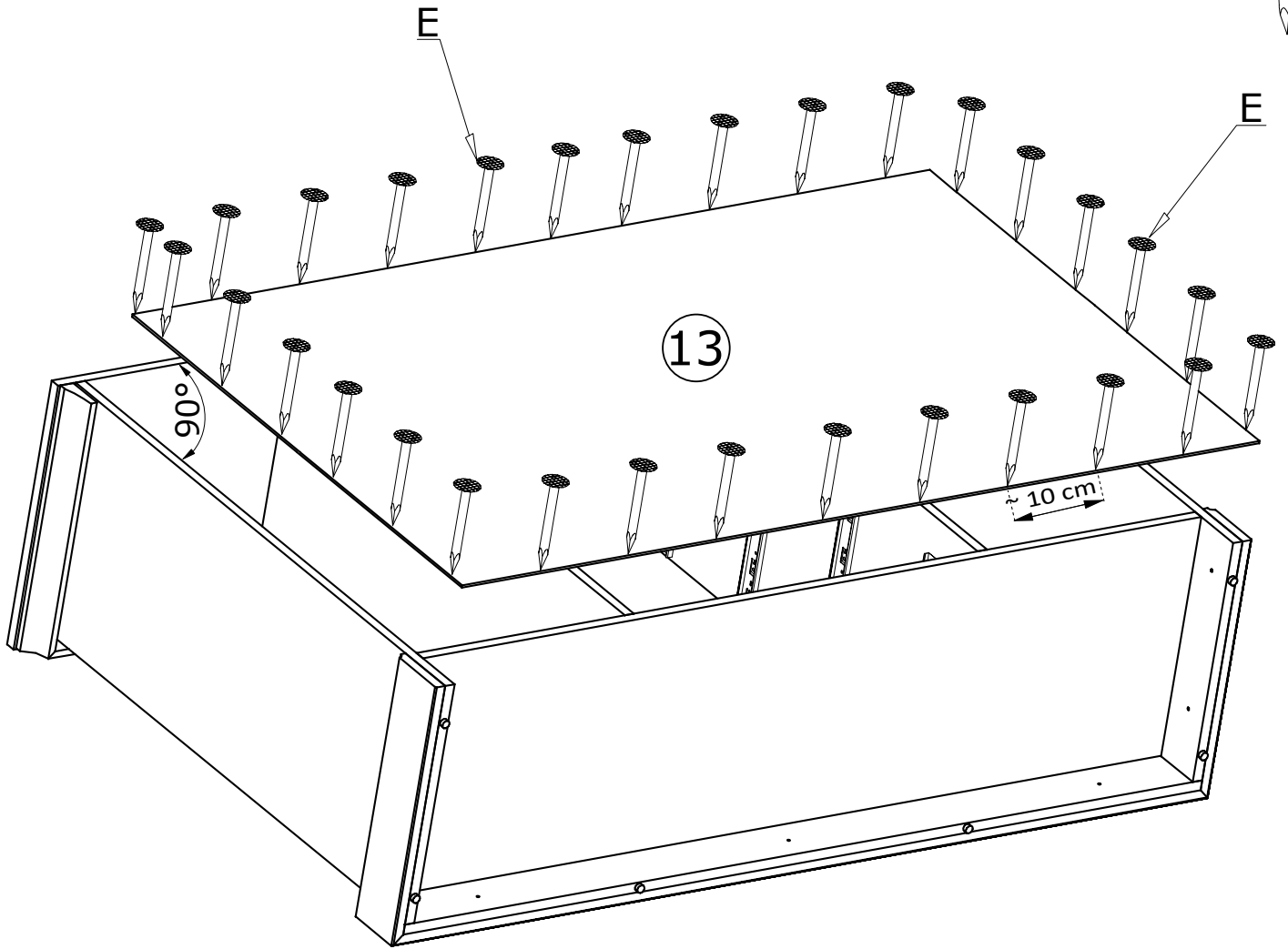

VIII

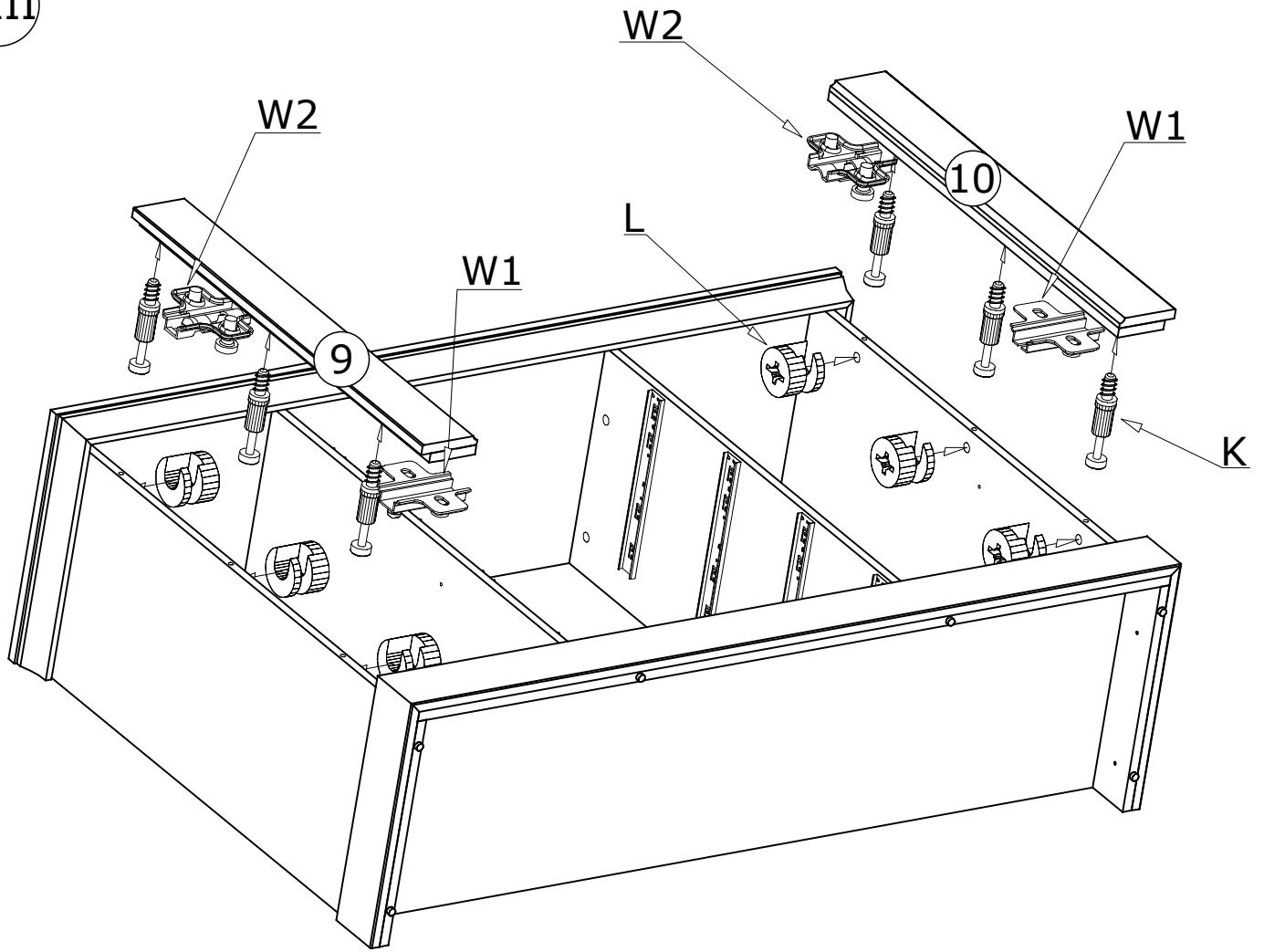

IX

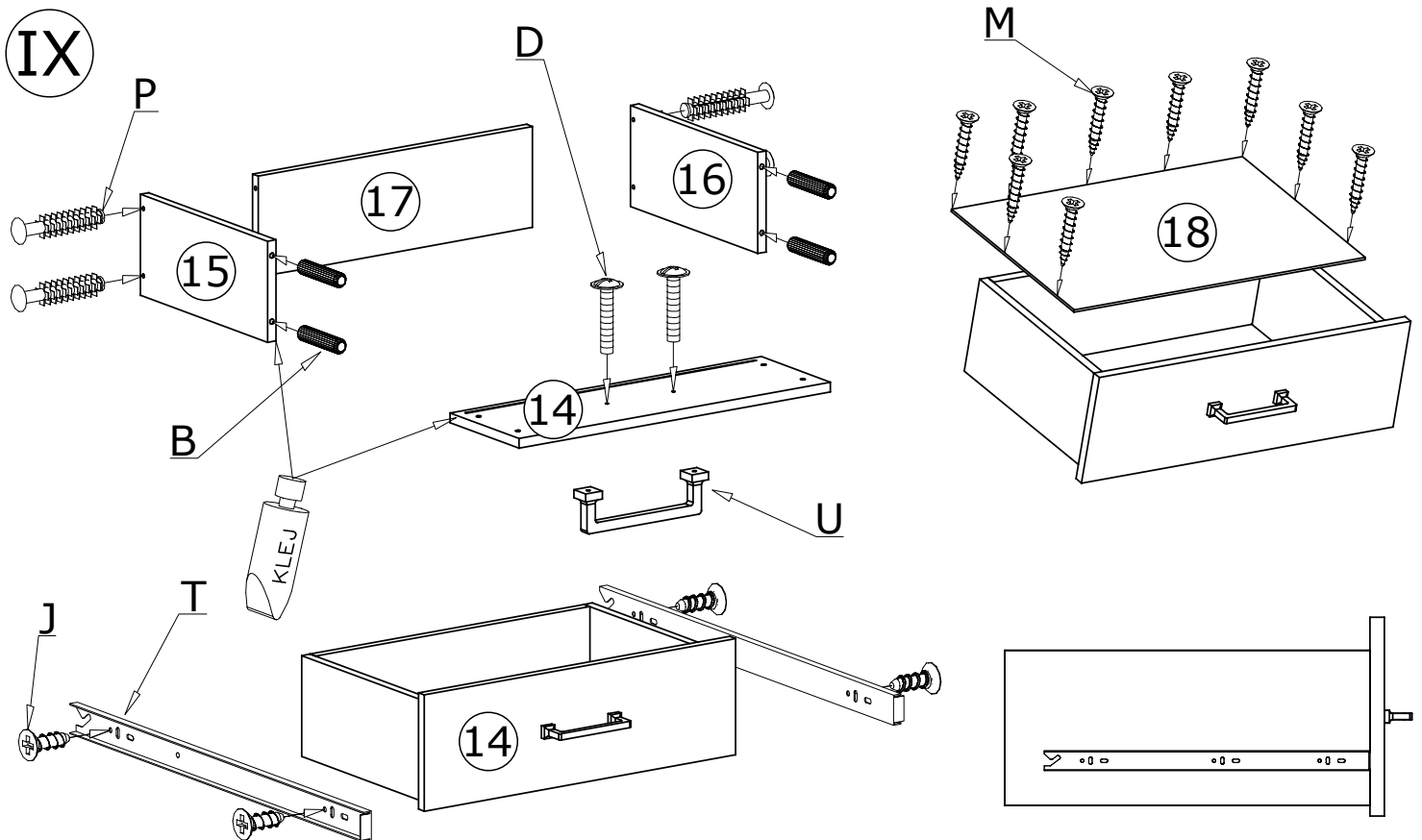

X

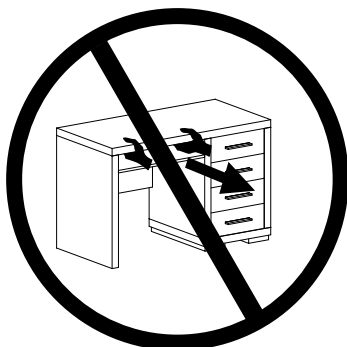
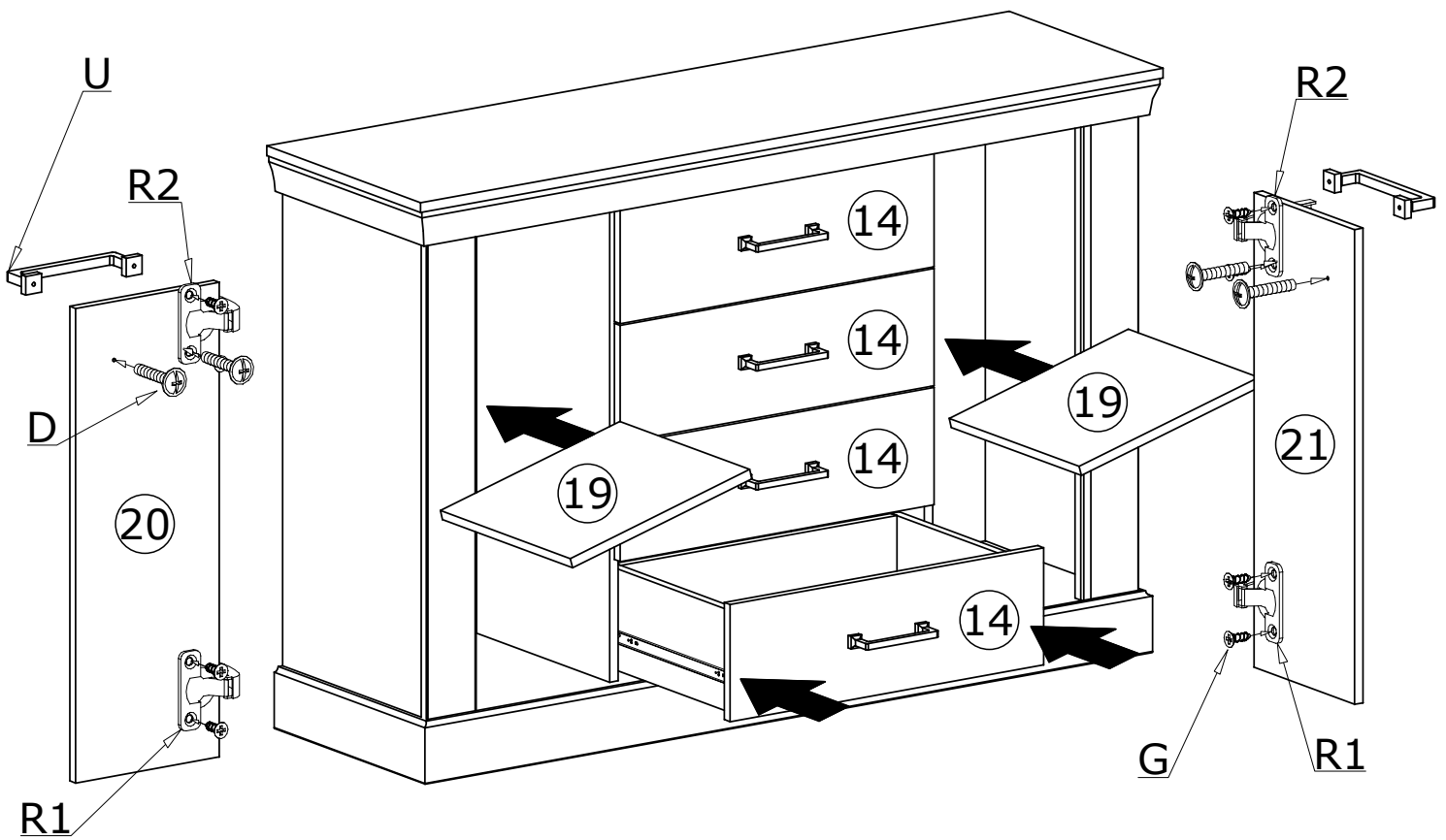

# MONTAŻ/DEMONTAŻ PROWADNIC

1



2



3

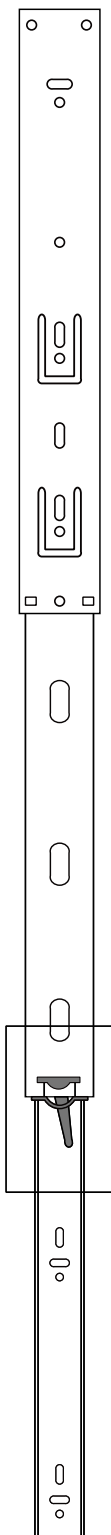

4

