

APOLLO 16

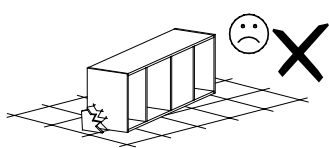

Narzędzia potrzebne do montażu

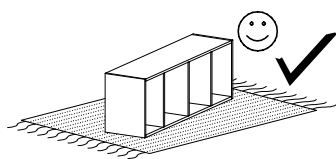
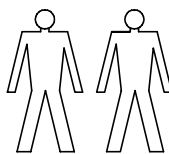
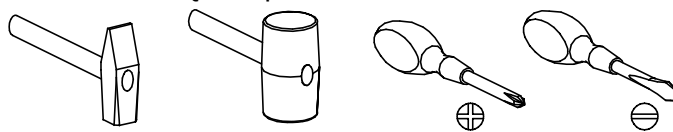

UWAGA !!!

MONTOWANIE USZKODZONYCH
ELEMENTÓW POWODUJE UTRATĘ
GWARANCJI

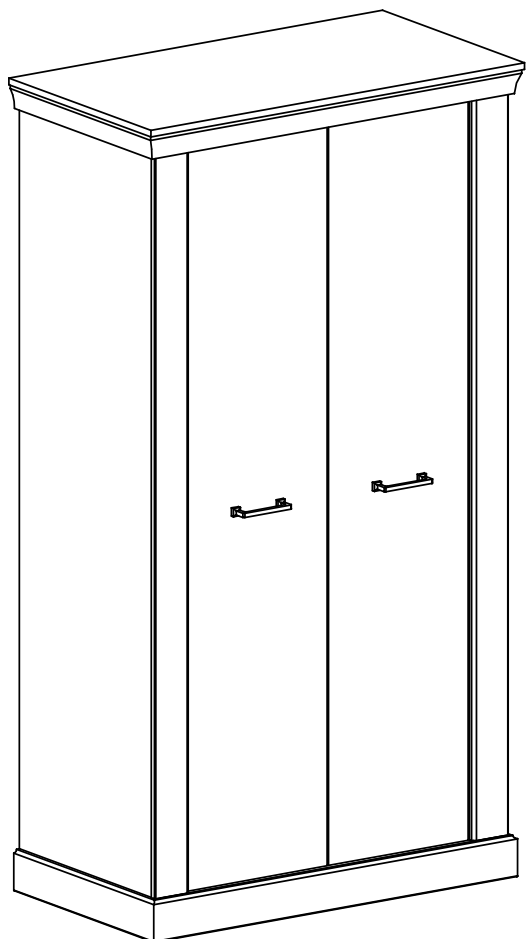

Nr	D[mm]	S[mm]	G[mm]	Ilość
1	1960	540	16	1
2	1960	540	16	1
3	977	557	16	1
4	977	523	16	2
5	1042	100	16	1
6	572	100	16	1
7	572	100	16	1
8	1070	580	71	1
9	977	120	16	1
10	1892	499	2,5	1
11	1865	100	32	1
12	1865	100	32	1
13	1800	400	16	1
14	1800	400	16	1
15	1008	80	16	1
16	810	55	16	1

W przypadku reklamacji proszę podać numer pakowacza znajdujący się na kartonie.

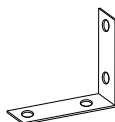

Y - 2 St.

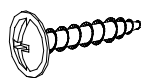

I - 4 St.
3,5x16 mm

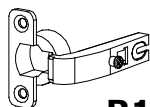

R1 - 4 St.



F - 1 St.

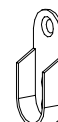

R - 2 St.

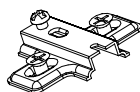

W1 - 4 St.

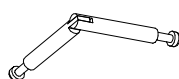

O - 4 St.



Ł - 1 St.



G - 25 St.
3,5x16 mm



L - 36 St.



E - 50 St.



A - 14 St.
7x50 mm

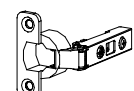

R2 - 4 St.



W2 - 4 St.

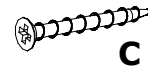

C - 10 St.
3,9x30 mm



B - 24 St.
8x35 mm

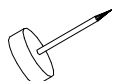

Q - 5 St.

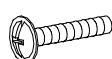

D - 4 St.
4x25 mm

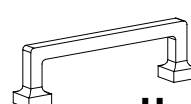

U - 2 St.

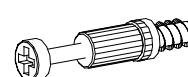

K - 28 St.

I

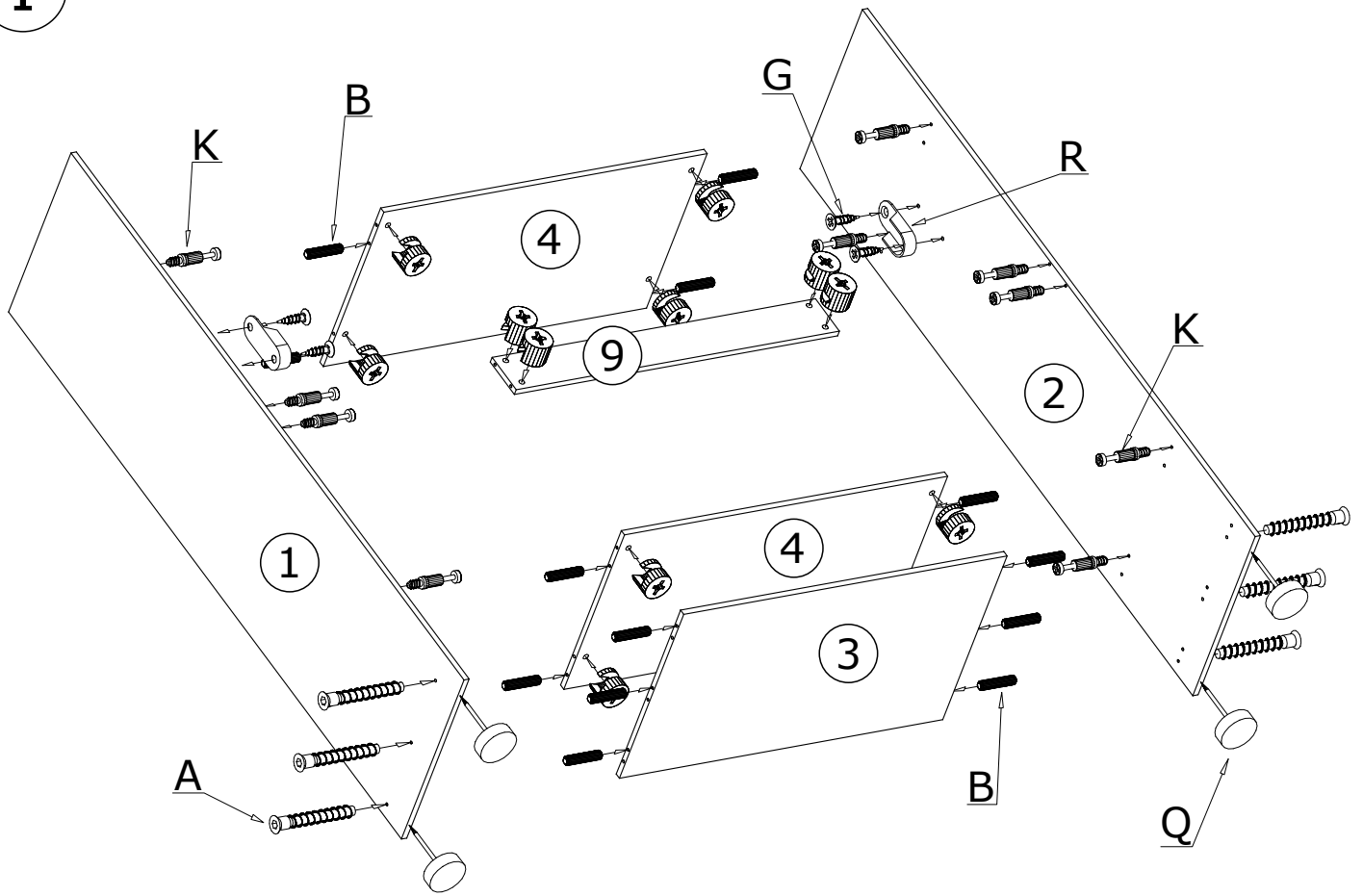

II

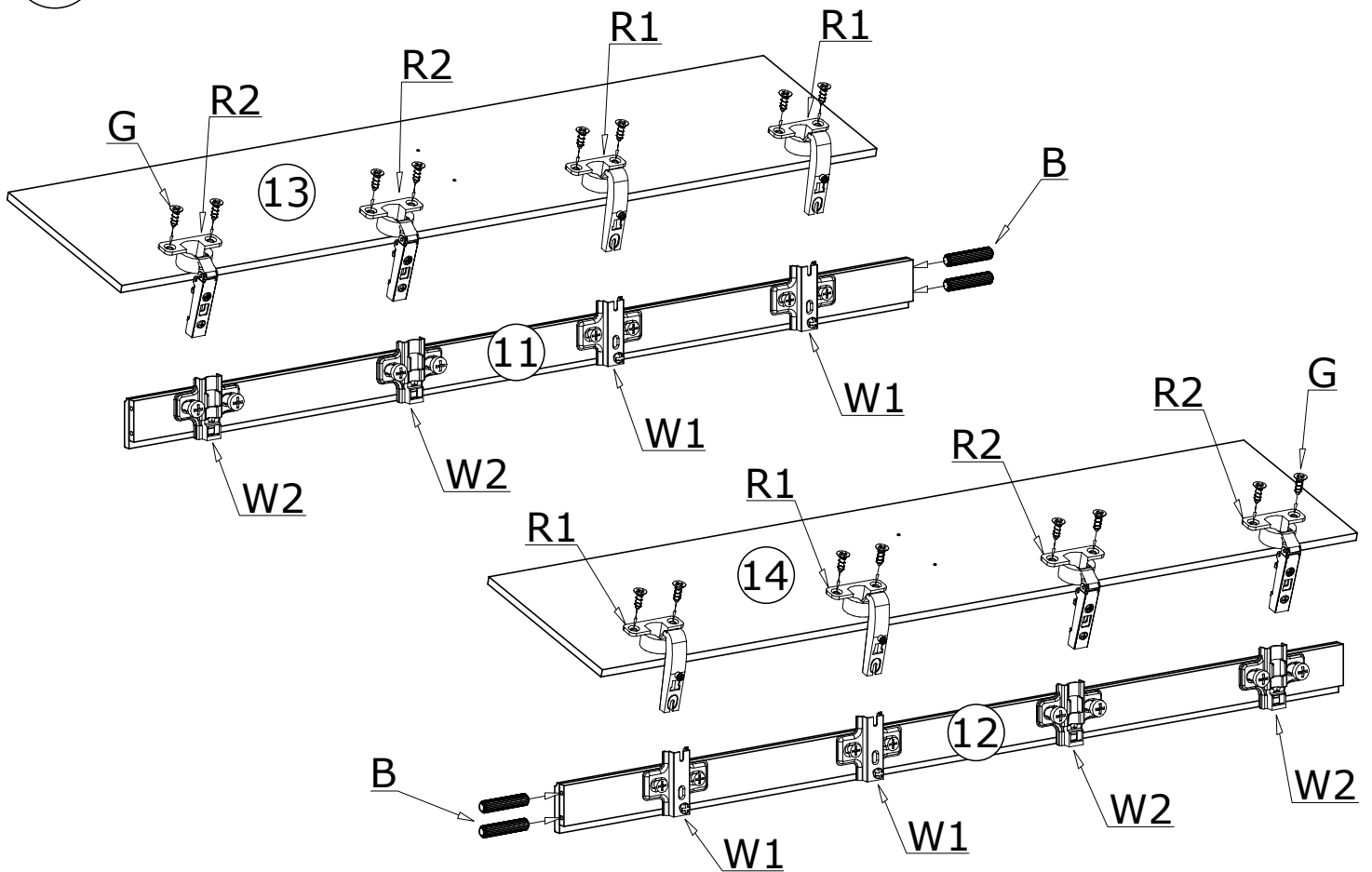

III

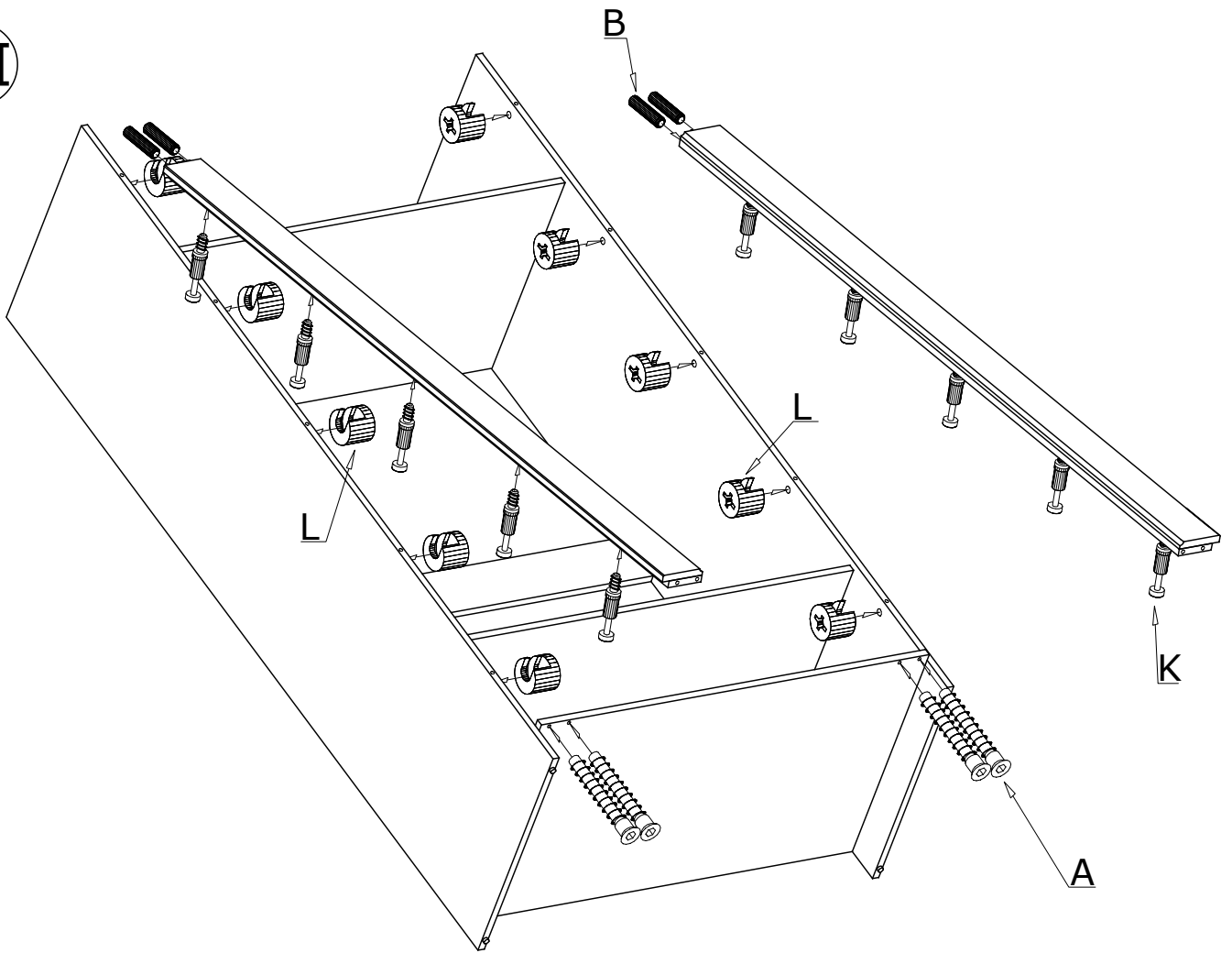

IV

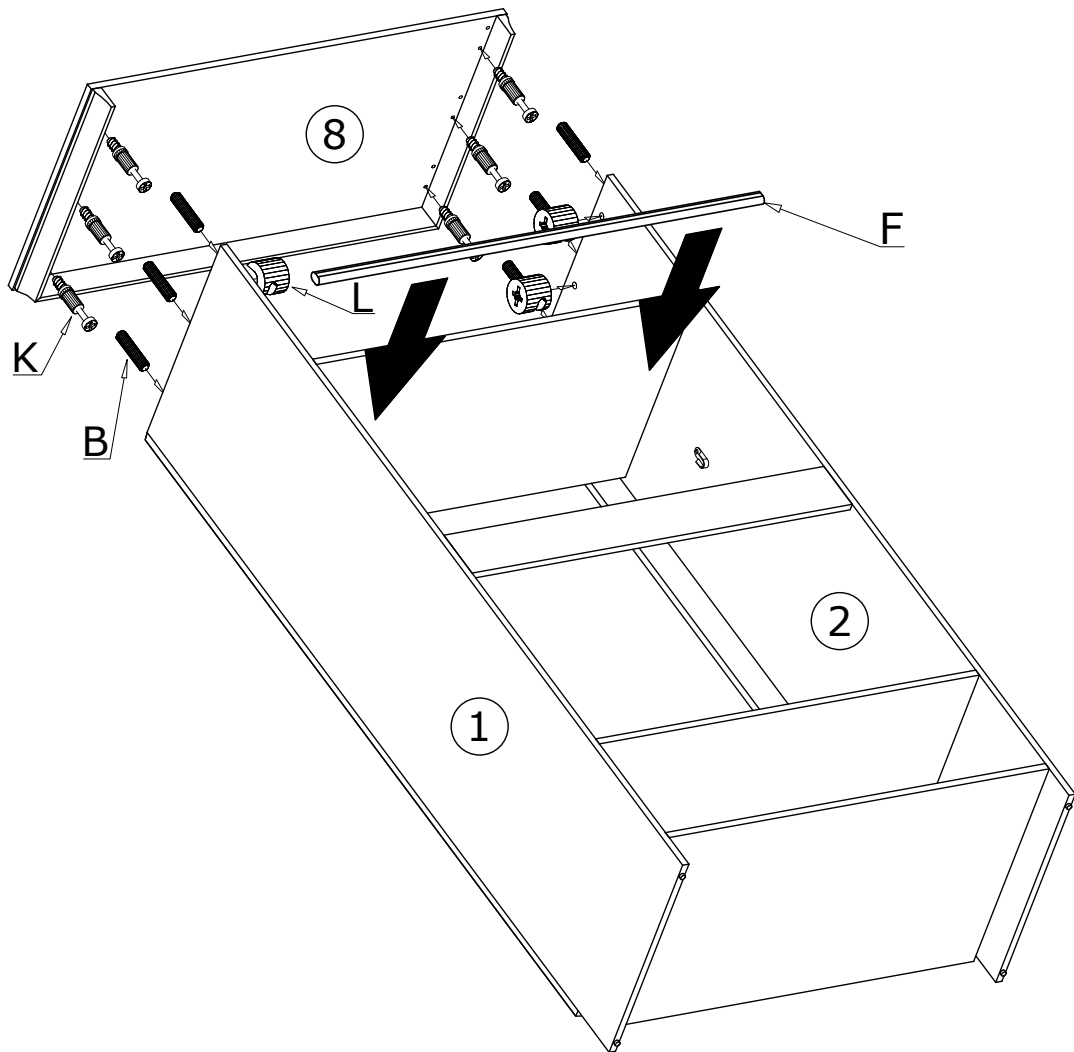

V

50X 

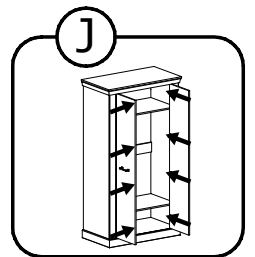
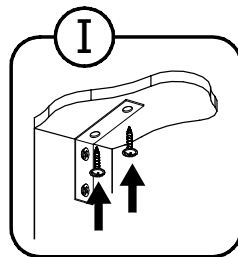
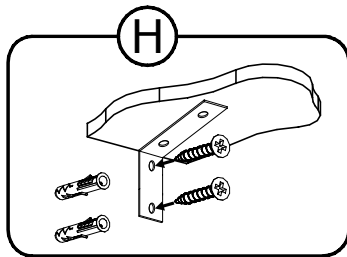
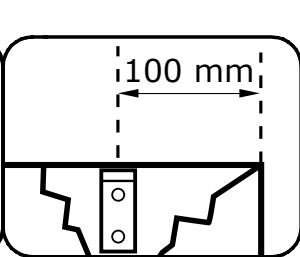
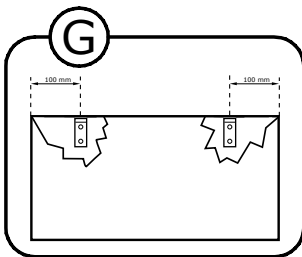
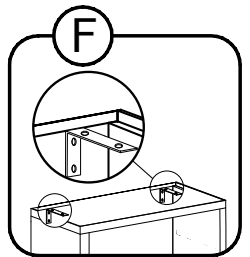
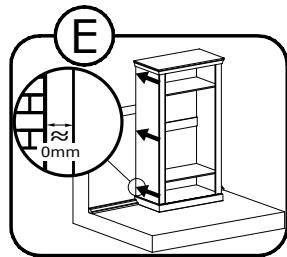
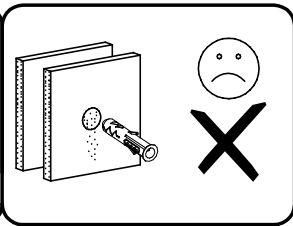
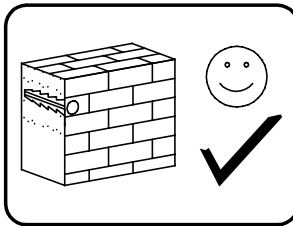
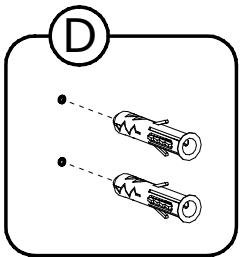
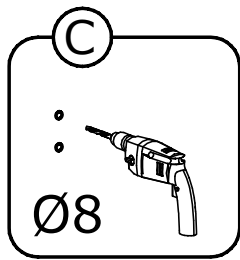
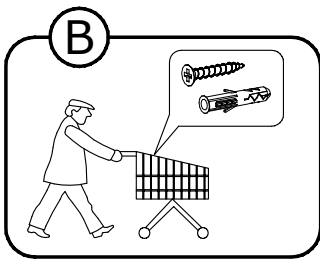
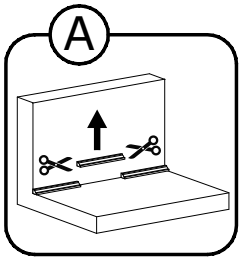
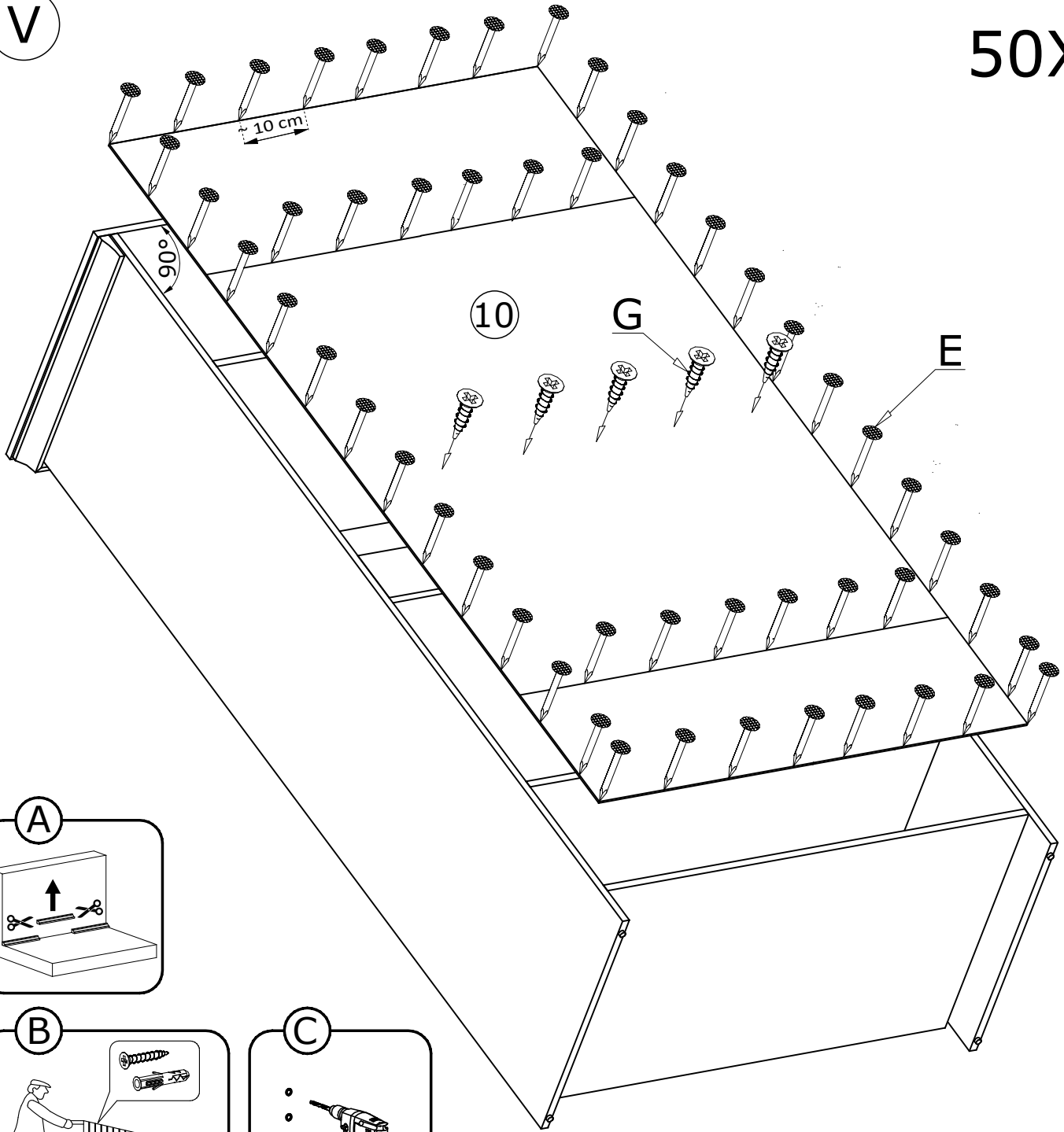

VI

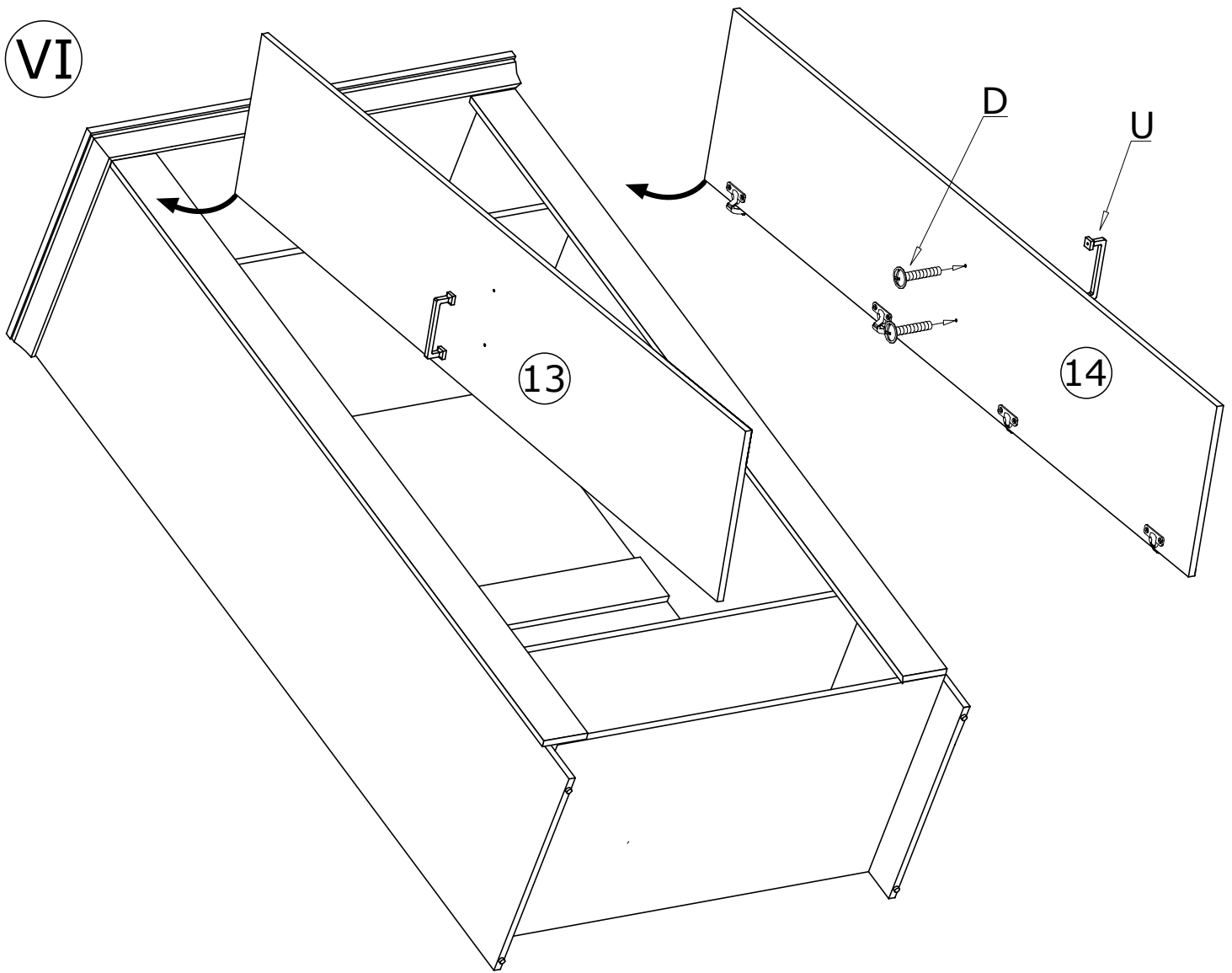

VII

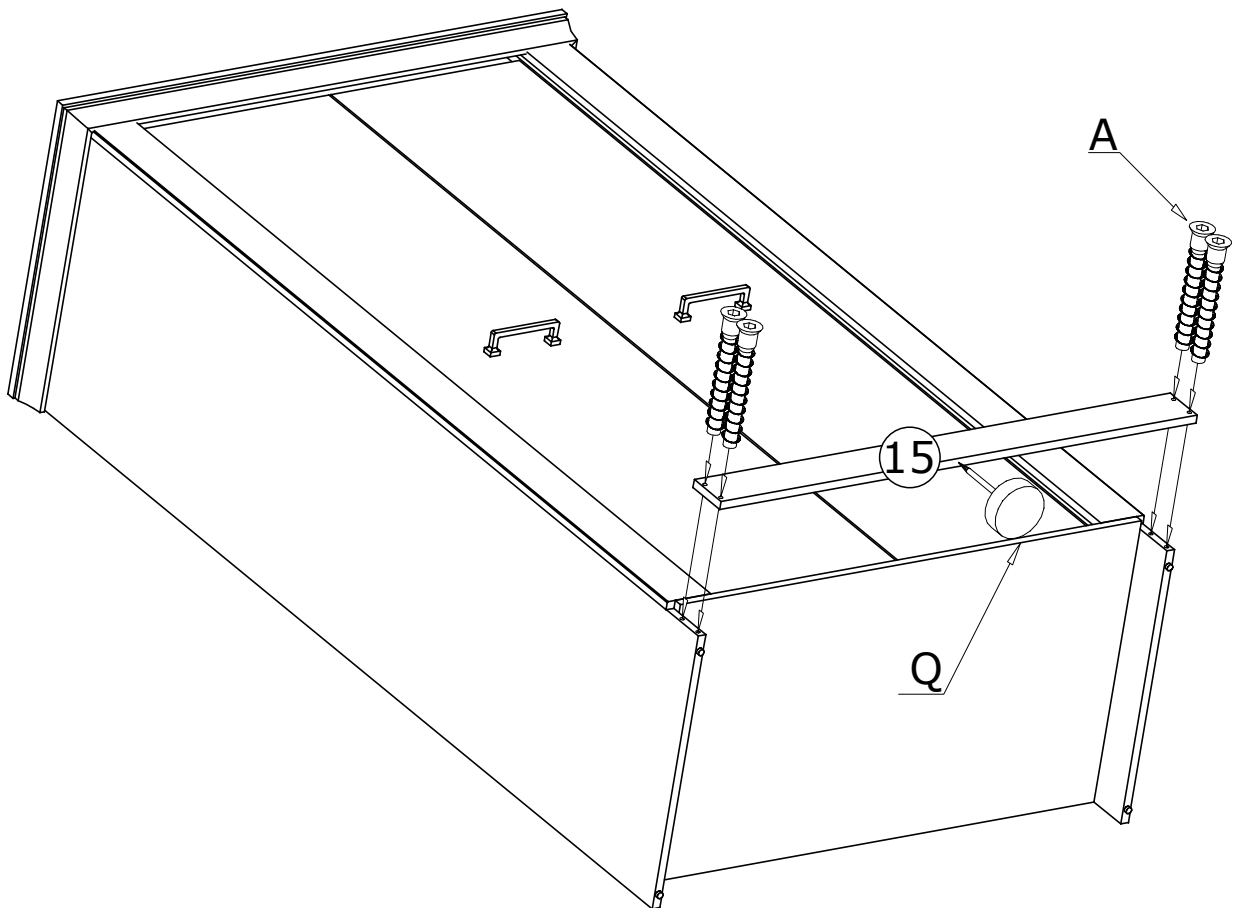

VIII

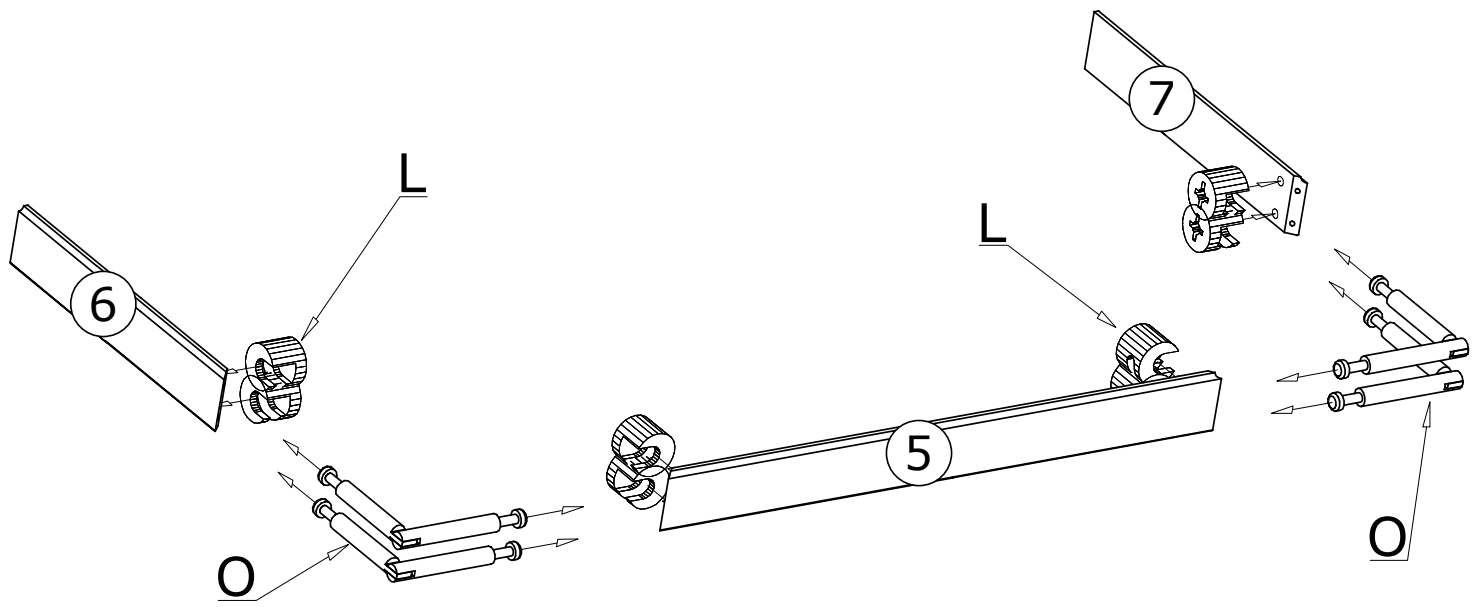

IX

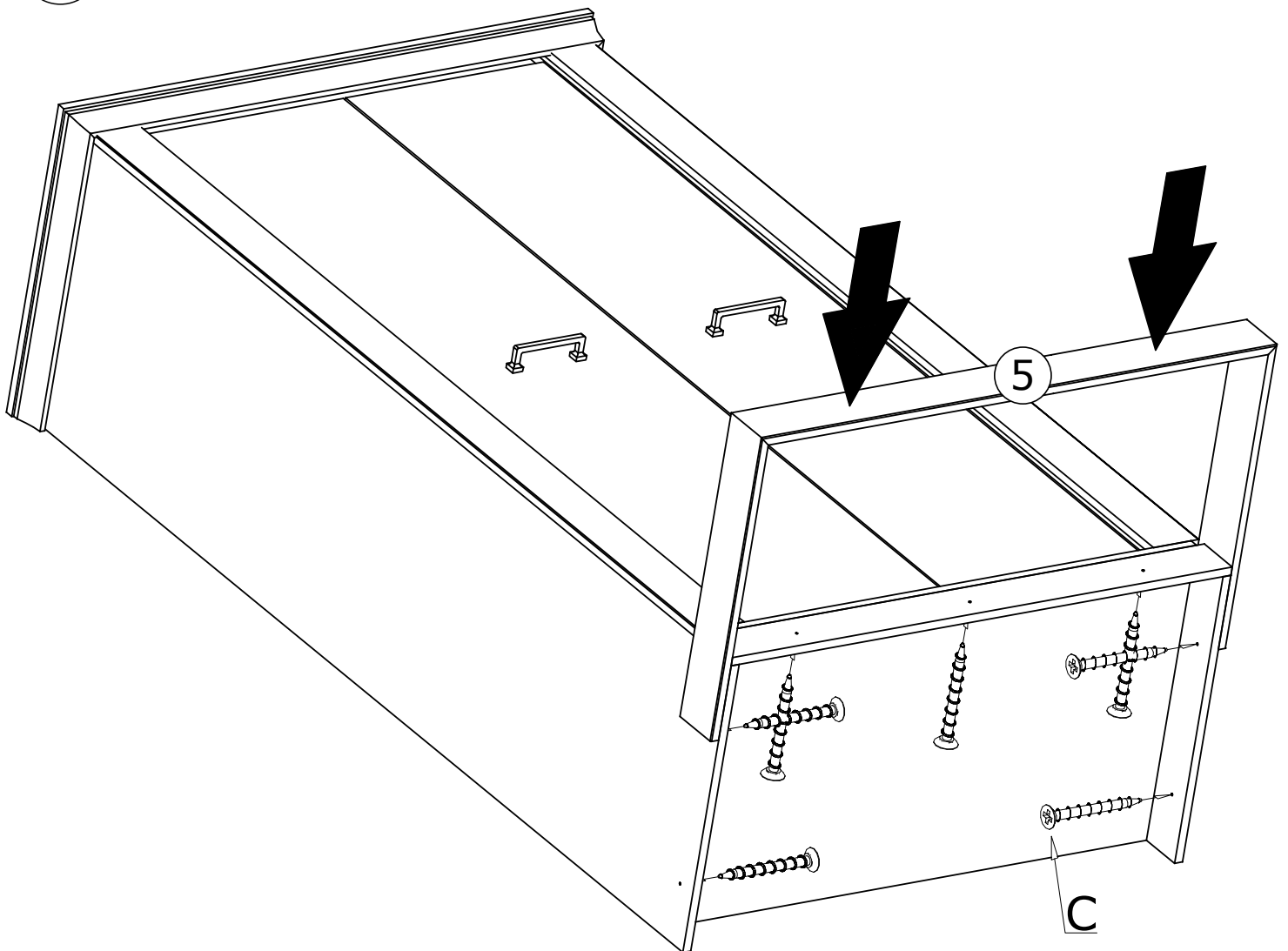

X

