

APOLLO 11

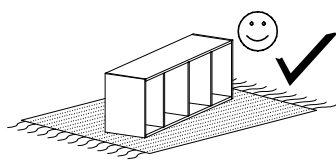

Narzędzia potrzebne do montażu

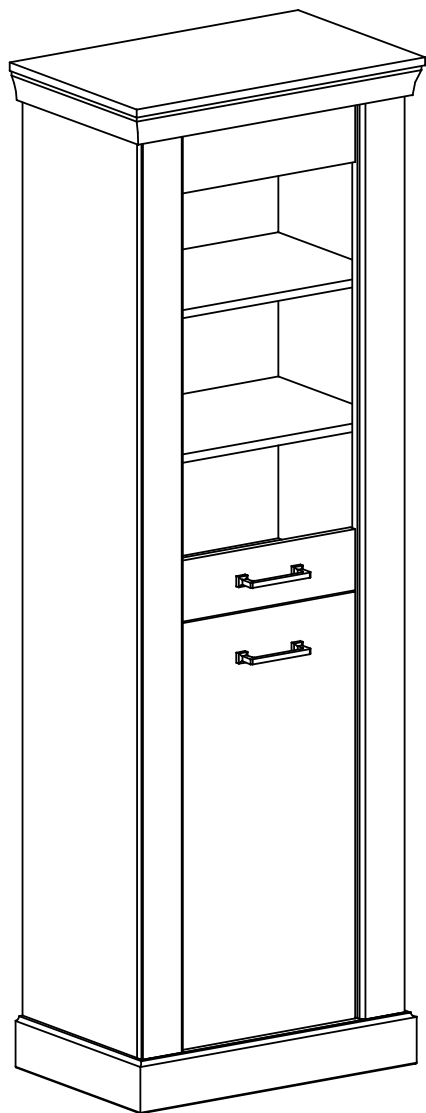

UWAGA !!!

MONTOWANIE USZKODZONYCH
ELEMENTÓW POWODUJE UTRATĘ
GWARANCJI

Nr	D[mm]	S[mm]	G[mm]	Ilość
1	665	420	71	1
2	574	396	16	1
3	574	364	16	1
4	1960	380	16	1
5	1960	380	16	1
6	410	100	16	1
7	410	100	16	1
8	640	100	16	1
9	605	80	16	1
10	1892	298	2,5	1
11	1865	100	32	1
12	1865	100	32	1
13	120	400	16	1
14	760	400	4	1
15	120	400	16	1
16	838	400	16	1
17	574	350	16	3
18	410	55	16	1

W przypadku reklamacji proszę podać numer pakowacza znajdujący się na kartonie.

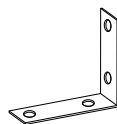

Y - 2 St.

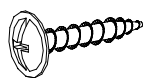

I - 4 St.
3,5x16 mm

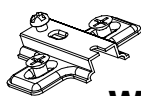

W1 - 2 St.

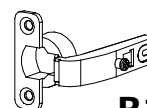

R1 - 2 St.

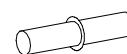

P - 12 St.

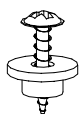

F - 6 St.

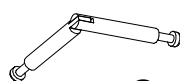

O - 4 St.



Ł - 1 St.



G - 8 St.
3,5x16 mm



L - 26 St.



E - 55 St.



A - 12 St.
7x50 mm

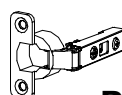

R2 - 2 St.



W2 - 2 St.

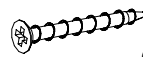

C - 8 St.
3,9x30 mm



B - 16 St.
8x36 mm

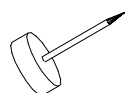

Q - 4 St.

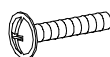

D - 4 St.
4x25 mm

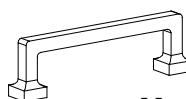

U - 2 St.

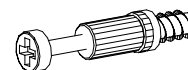

K - 18 St.

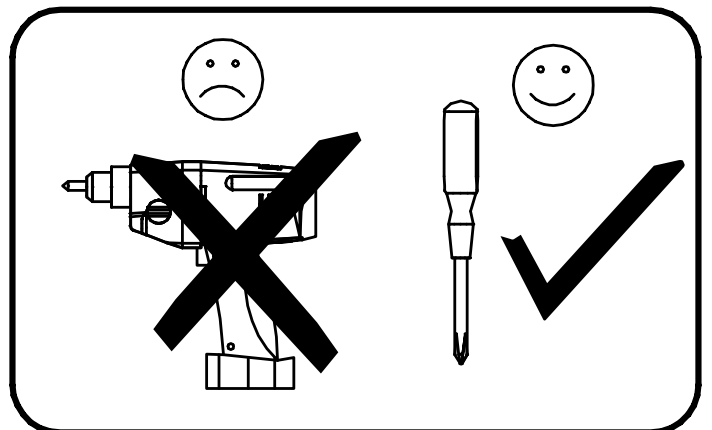
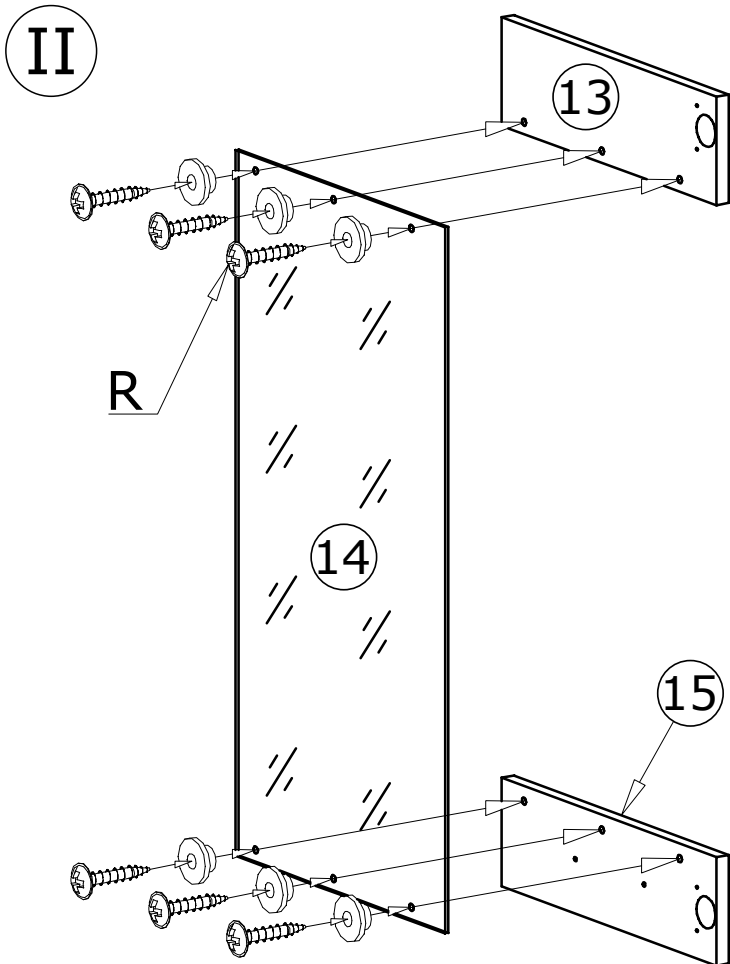
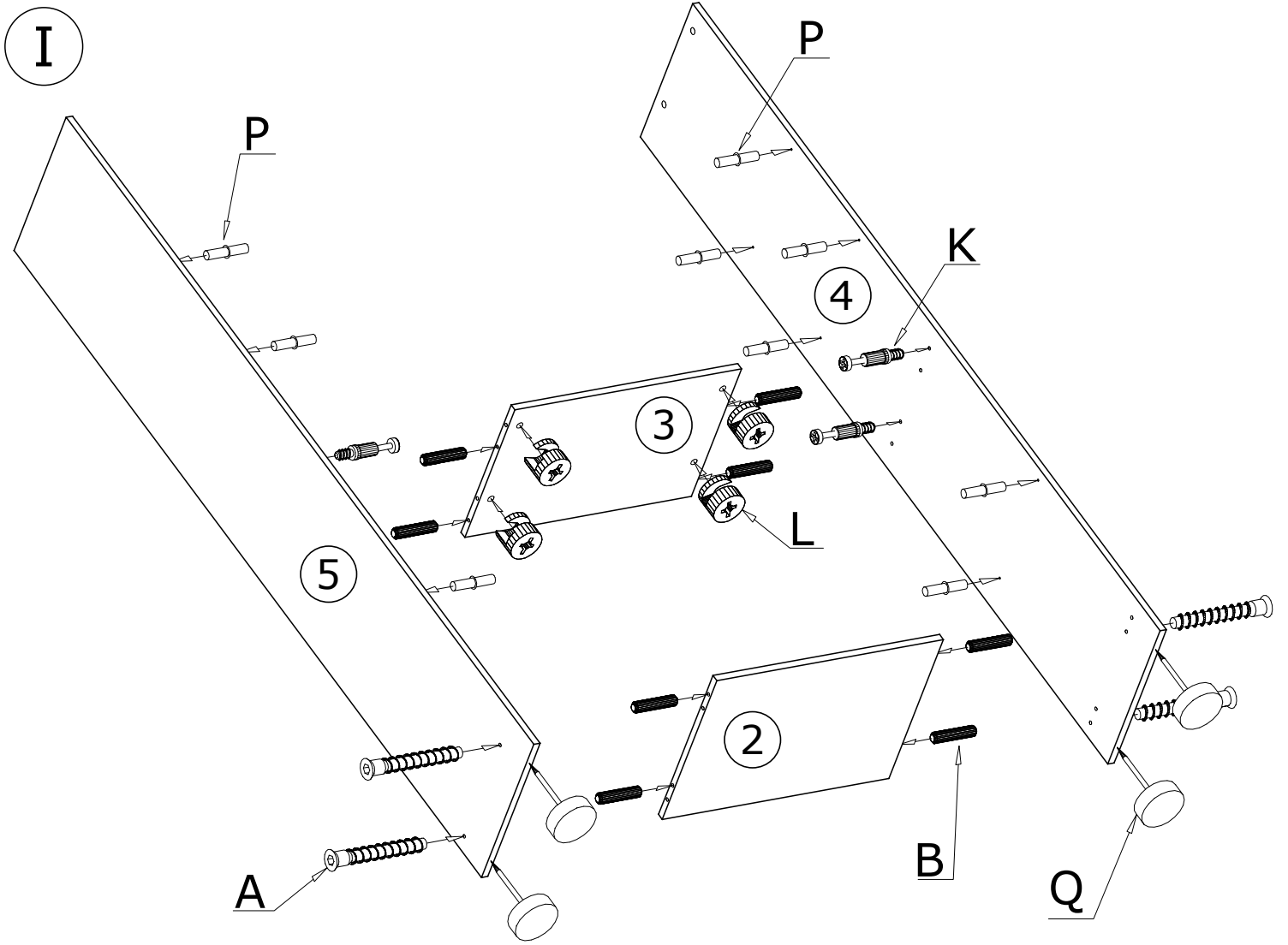

III

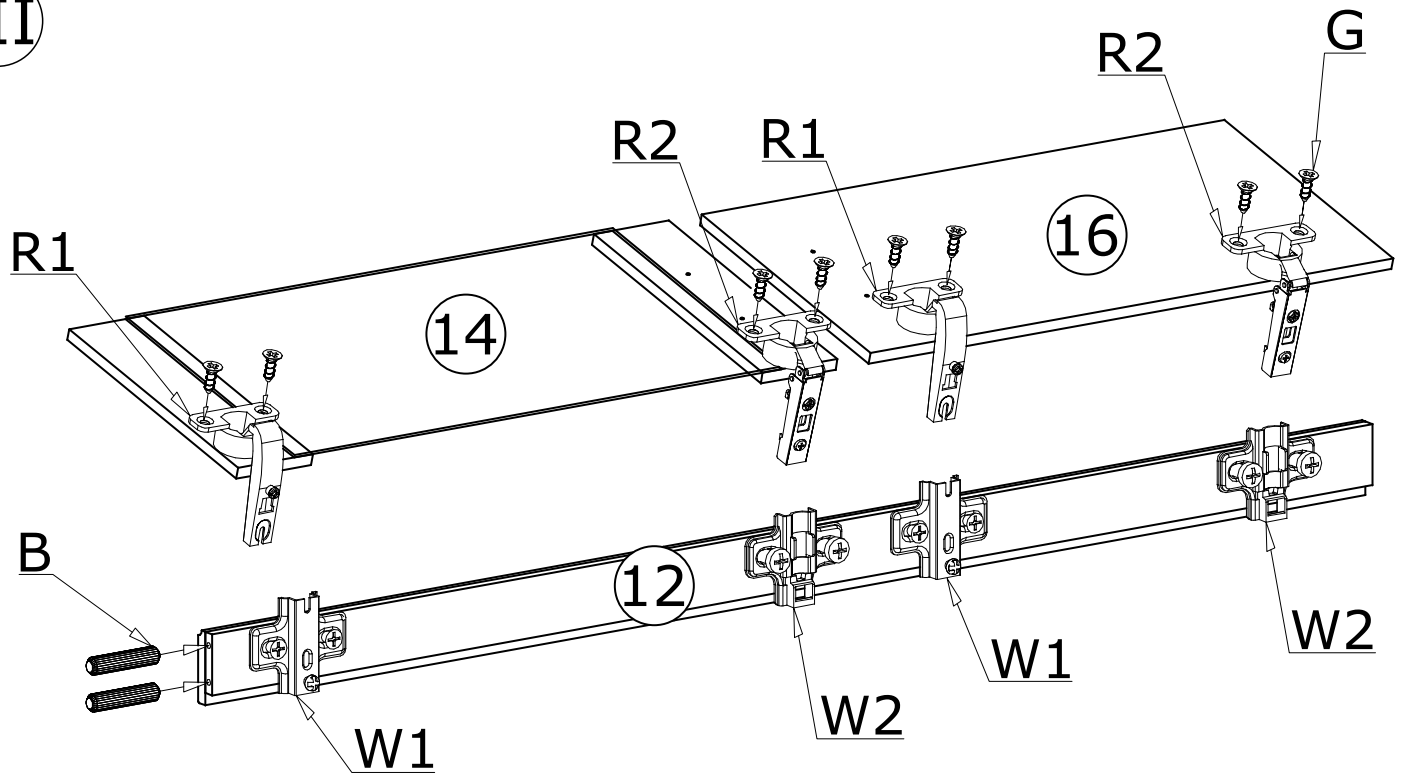

IV

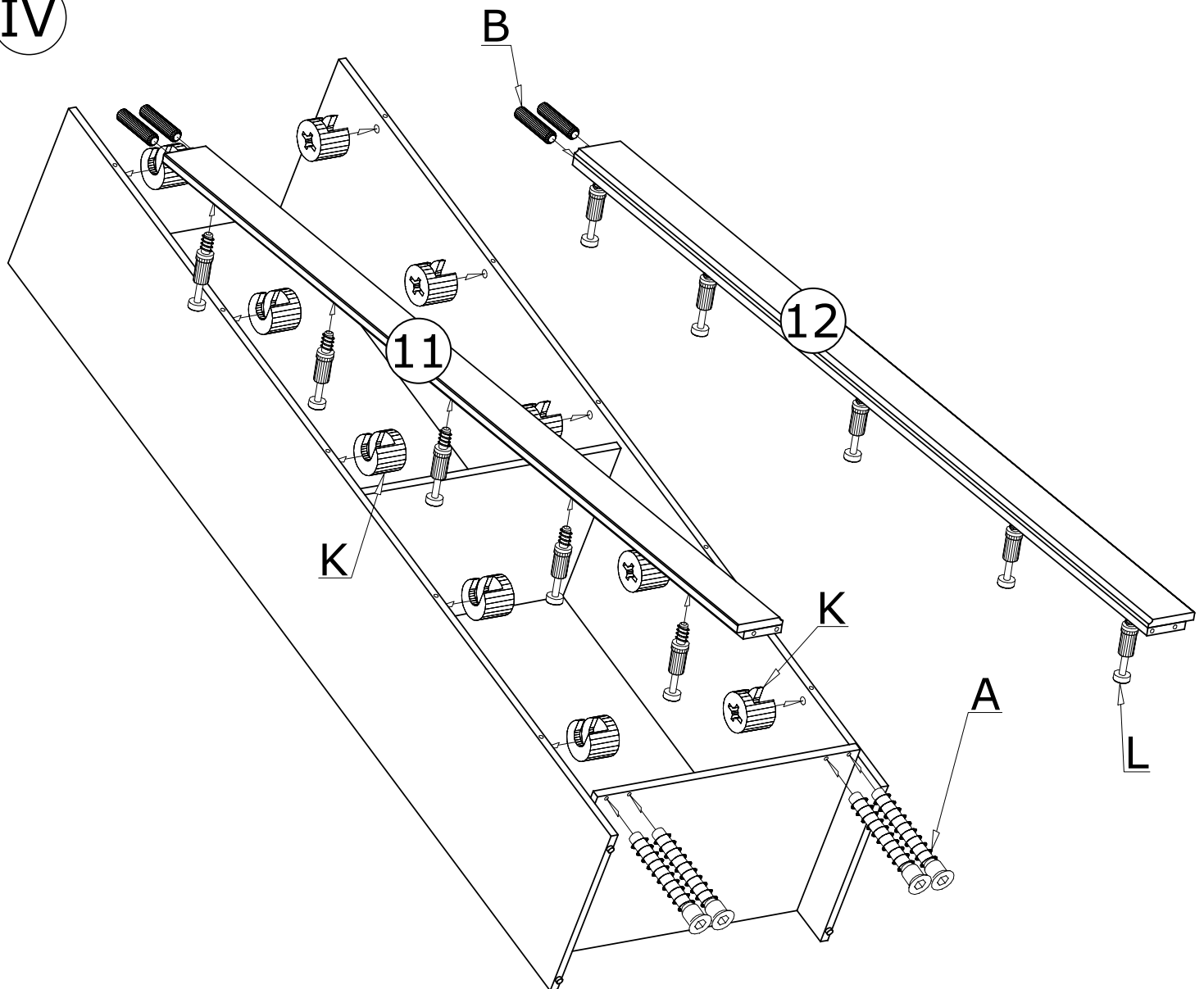

V

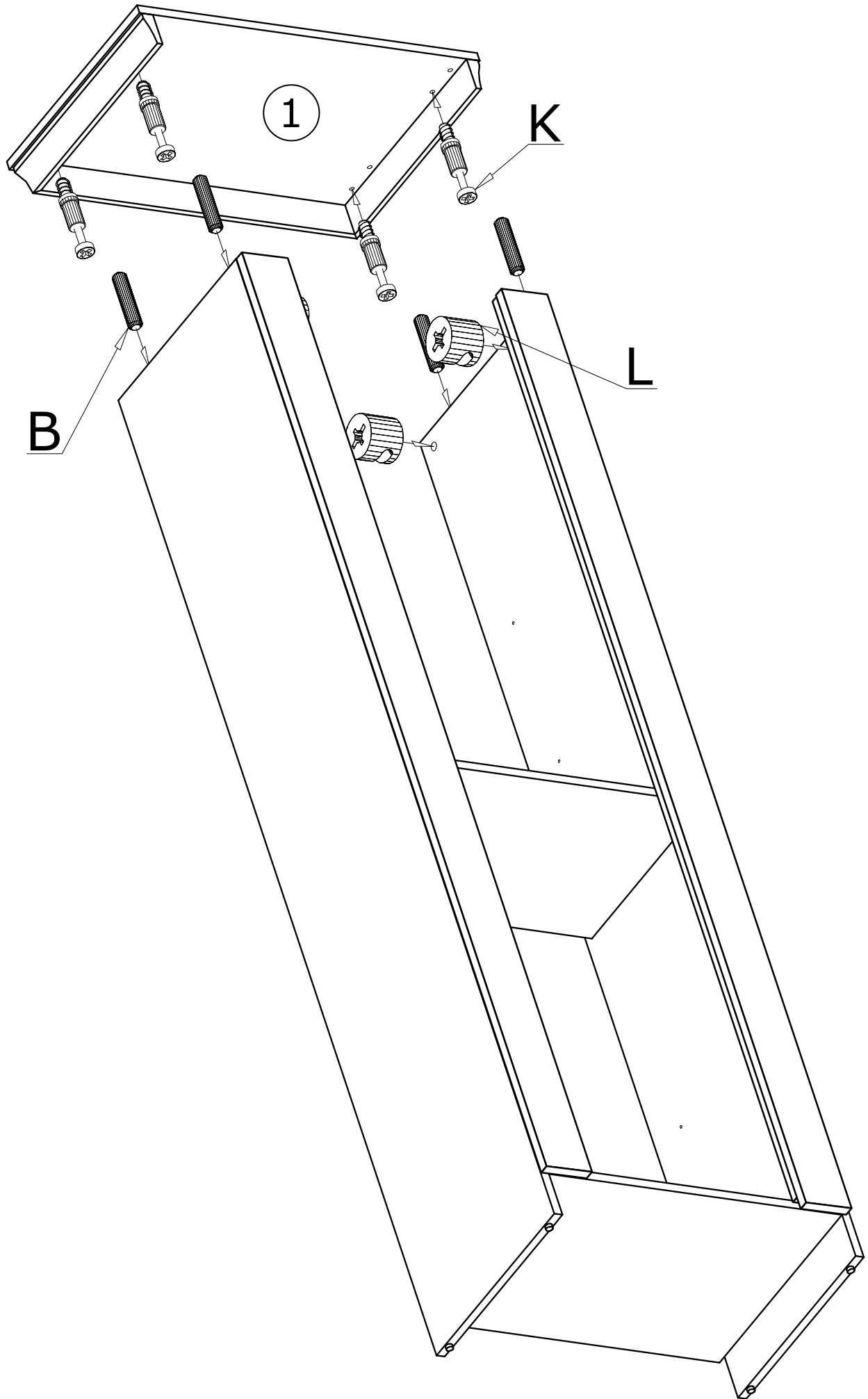

VI

55X 

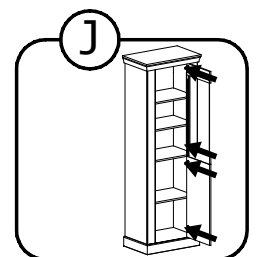
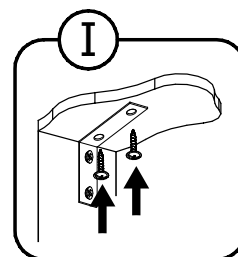
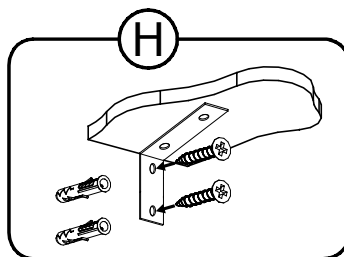
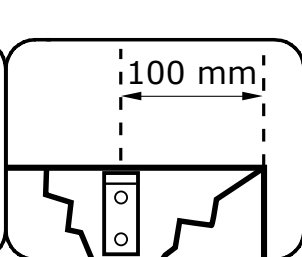
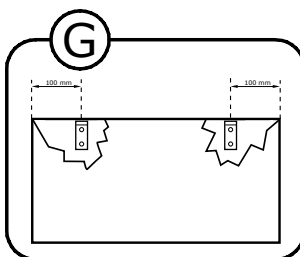
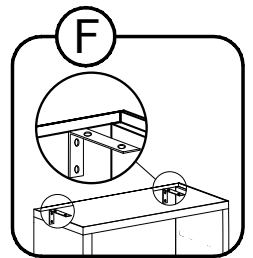
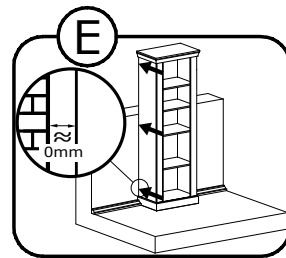
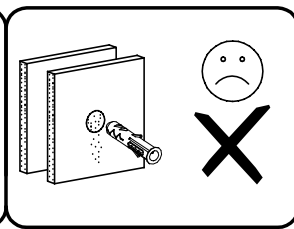
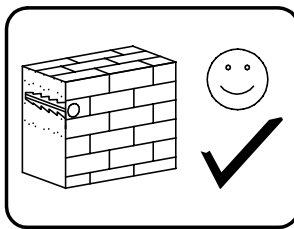
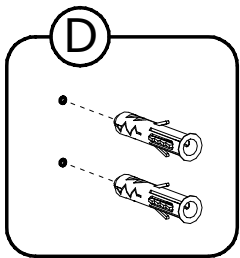
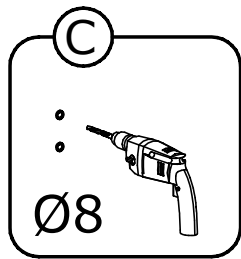
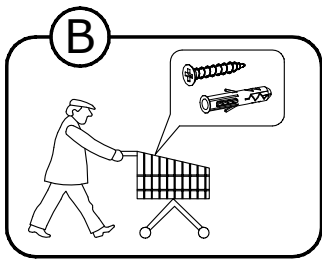
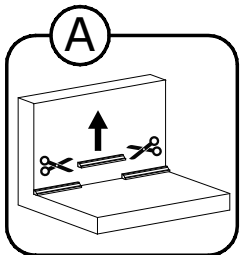
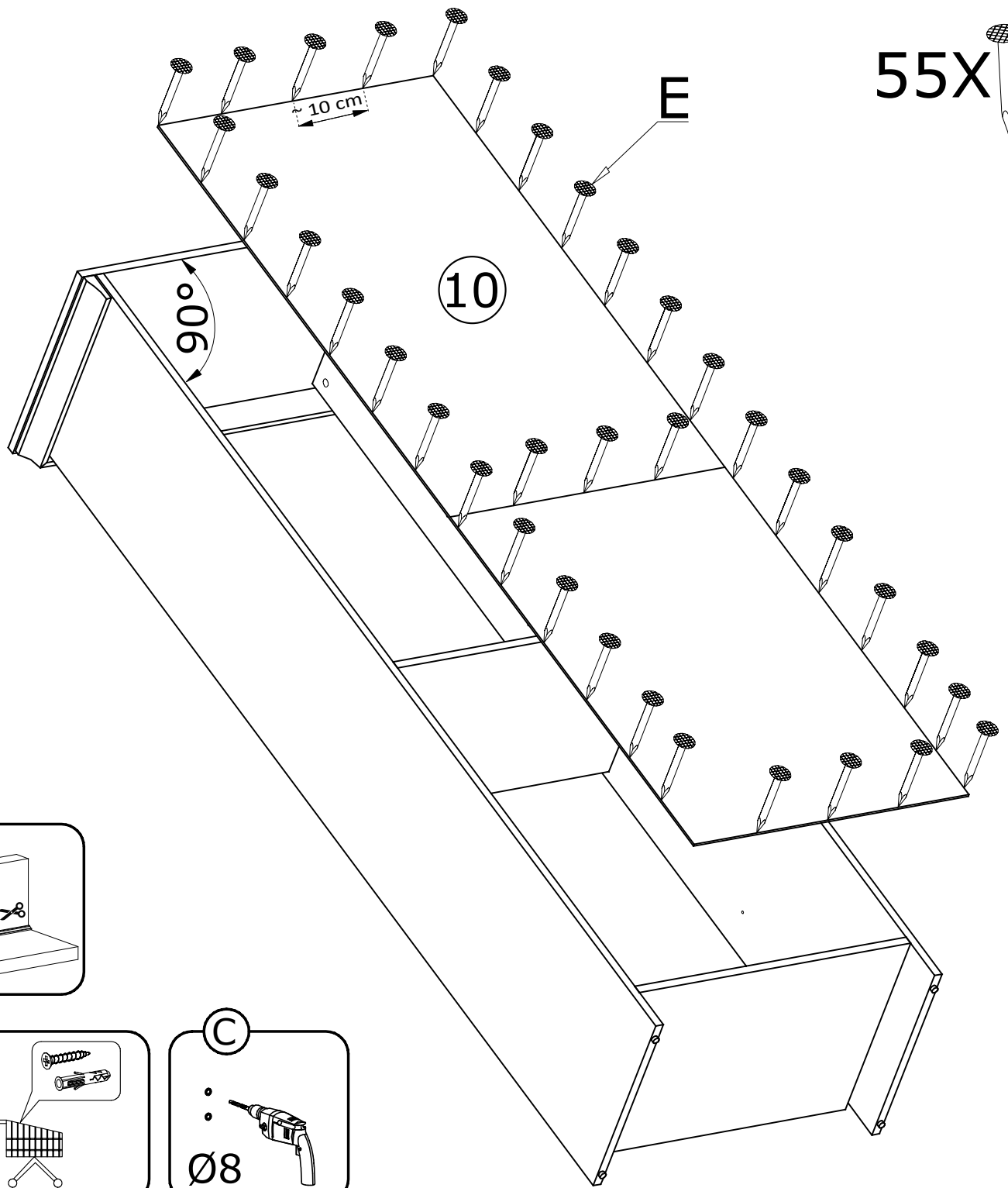

VII

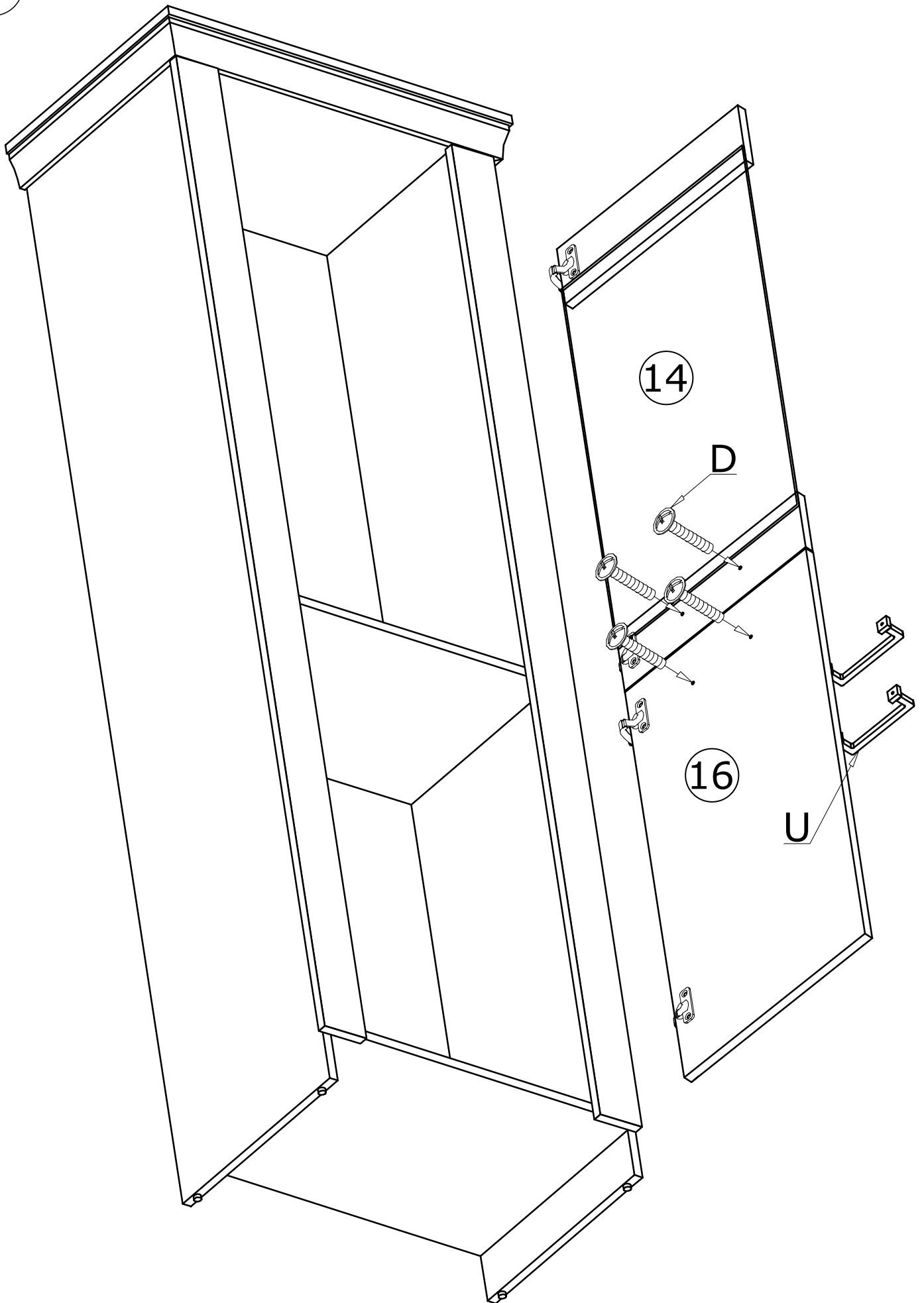

VIII

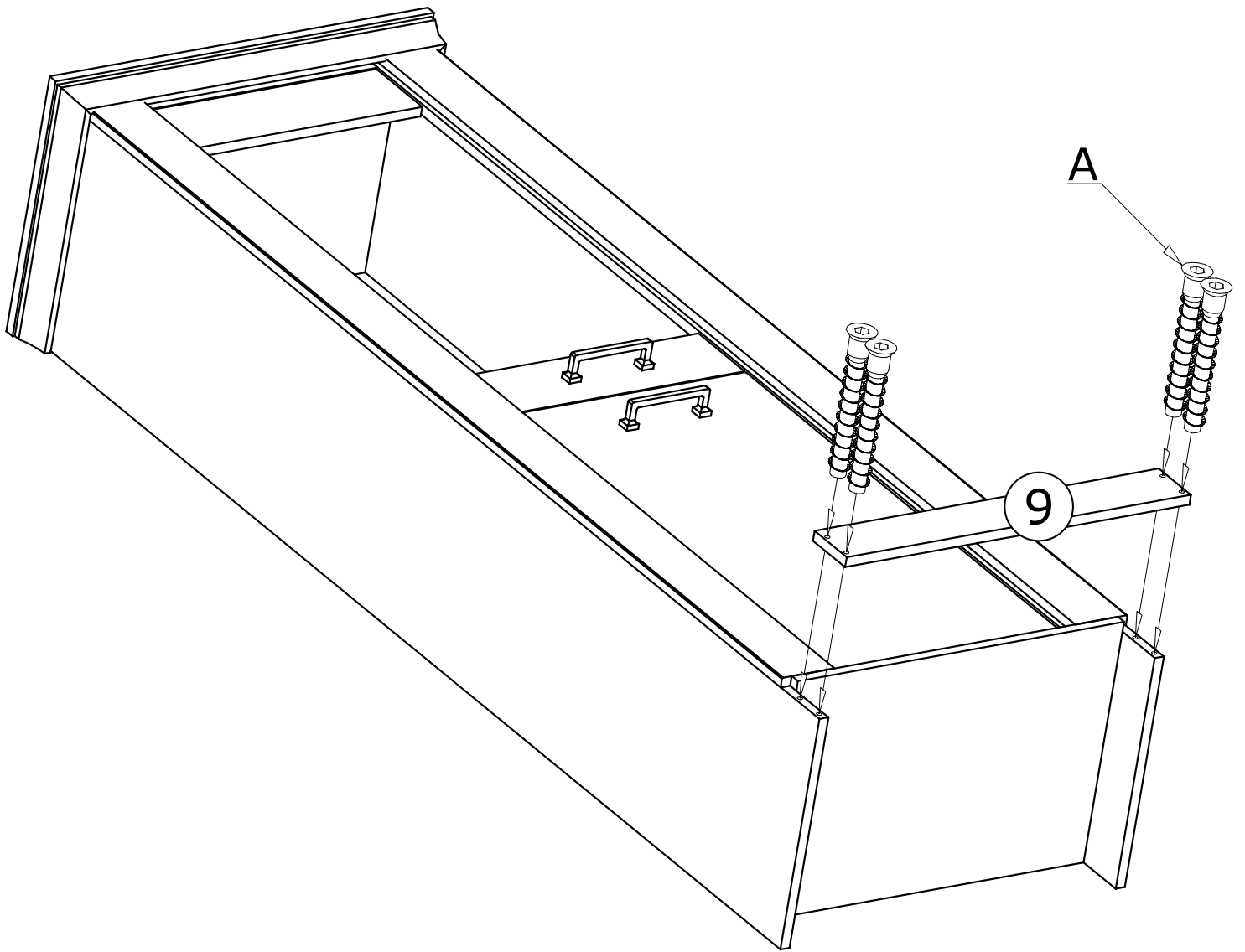

IX

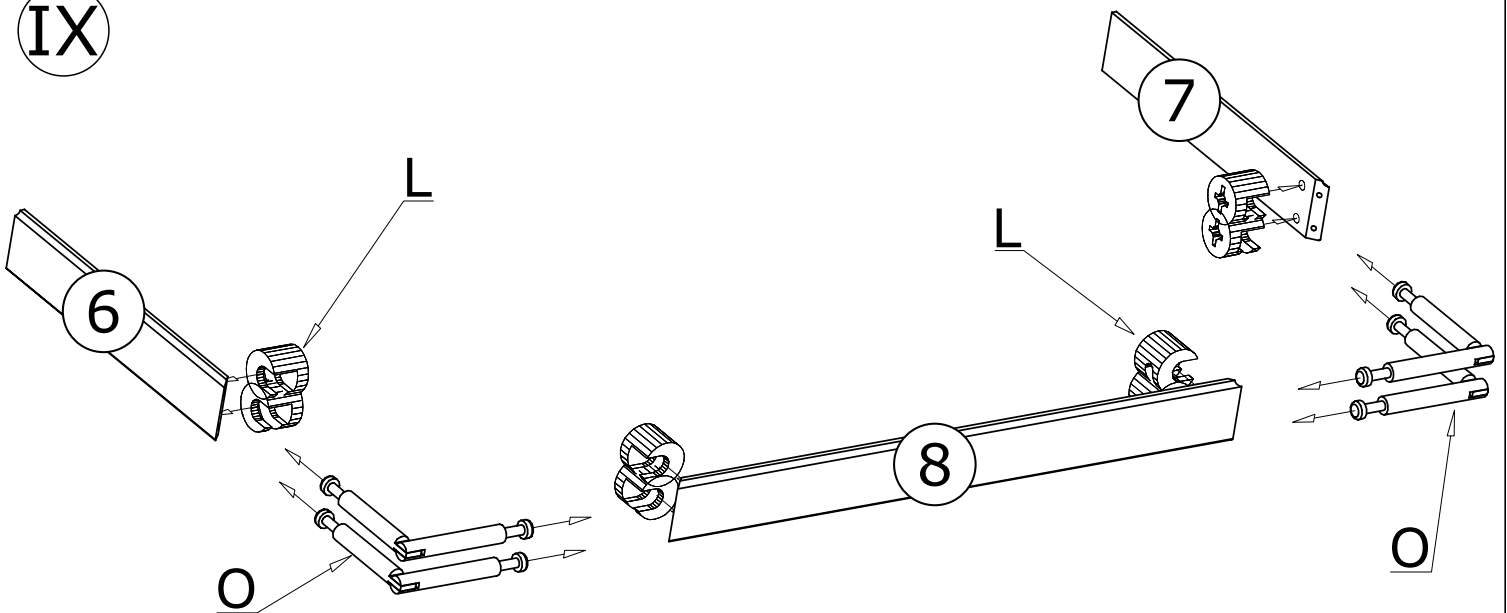

X

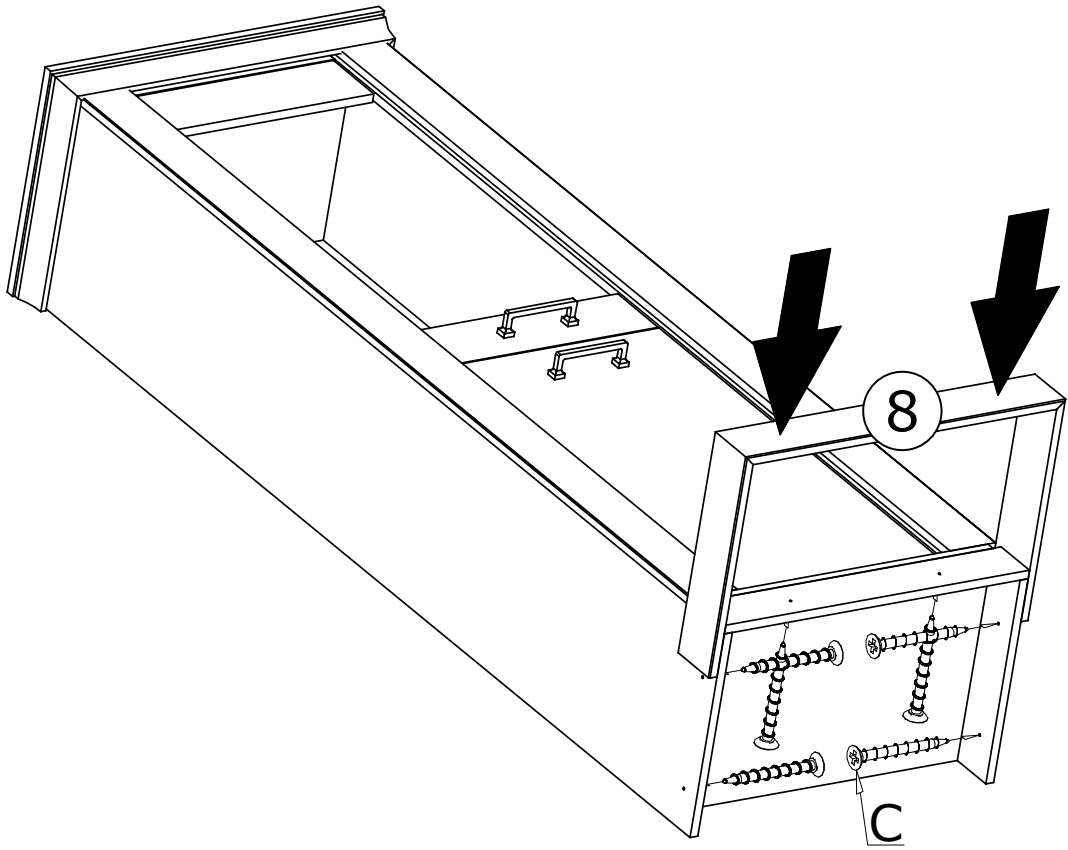

XI

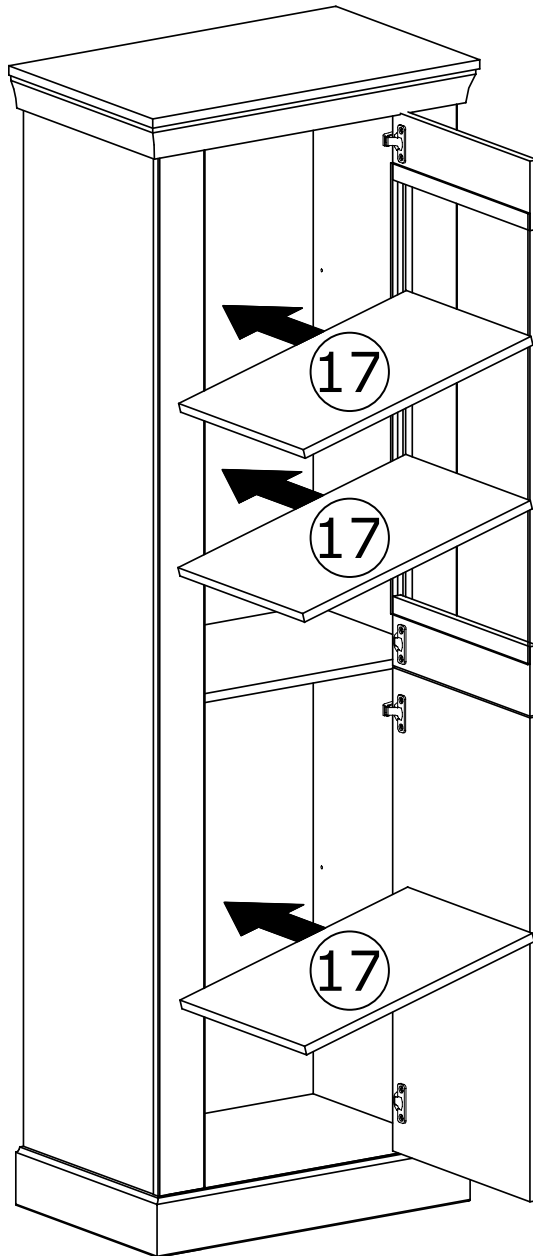

XII

